

Pro-Gear
VALVE ACTUATORS

THE POWER
IS YOURS!



MO-D SERIES

HOUSING
INPUT SHAFT
QUADRANT
WORM
STROKE ADJUSTMENT
EXCENTRIC RACK
COATING

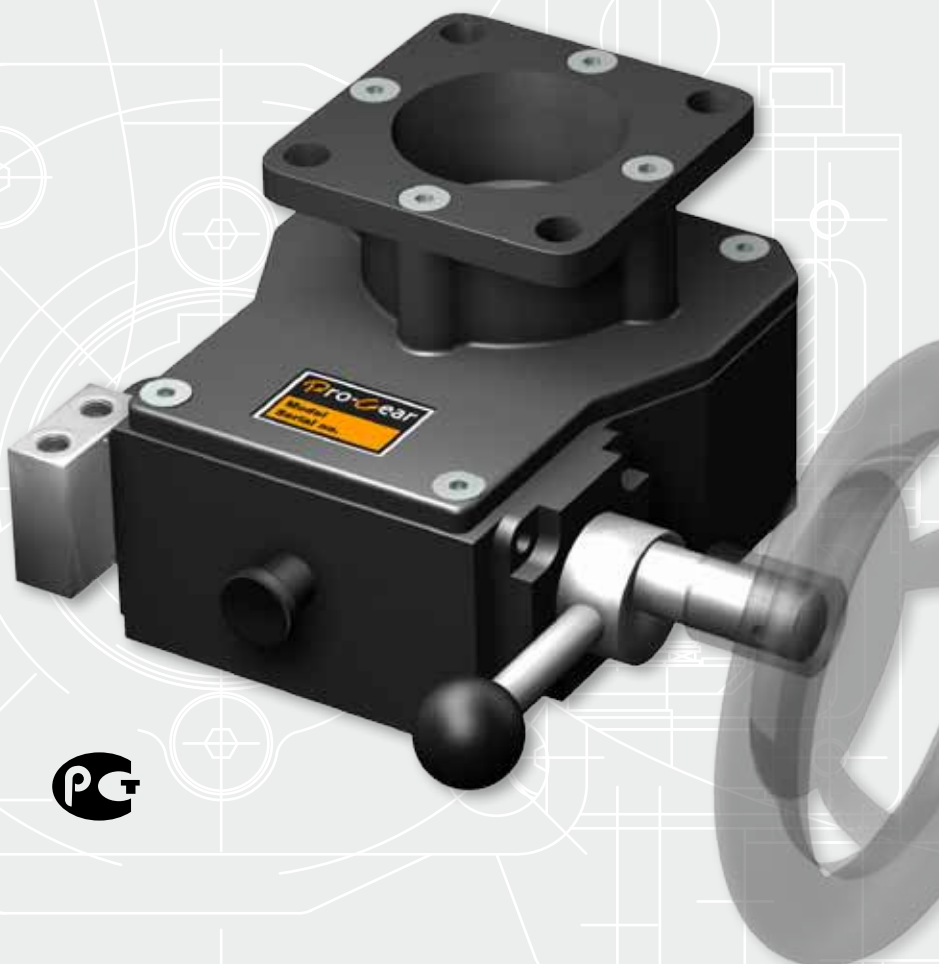



MO-D SERIES

The MO-D series are rugged, industrial grade manual overrides, manufactured with a cast iron housing. All models in this series feature high performance bearings and a polyurethane coated finish.

APPLICATIONS

The PRO-GEAR MO-D series is designed to provide a manual operation of 90° for shut-off valves which are equipped with a pneumatic- or hydraulic actuator.

The MO-D series is providing a declutchable design for use in all industries where a reliable operation of both double acting and spring return pneumatic actuators, as well as hydraulic actuators is required.

All units which are to be mounted between the valve and actuator will be supplied with a (interchangeable) actuator mounting flange for flexible usage. Furthermore, all units can be supplied with the ISO drive shaft which is connecting the actuator with the valve.

Optionally, a 3/2 relief valve can be fitted on the housing in order to automatically evacuate air pressure from the actuator while engaging the manual override.

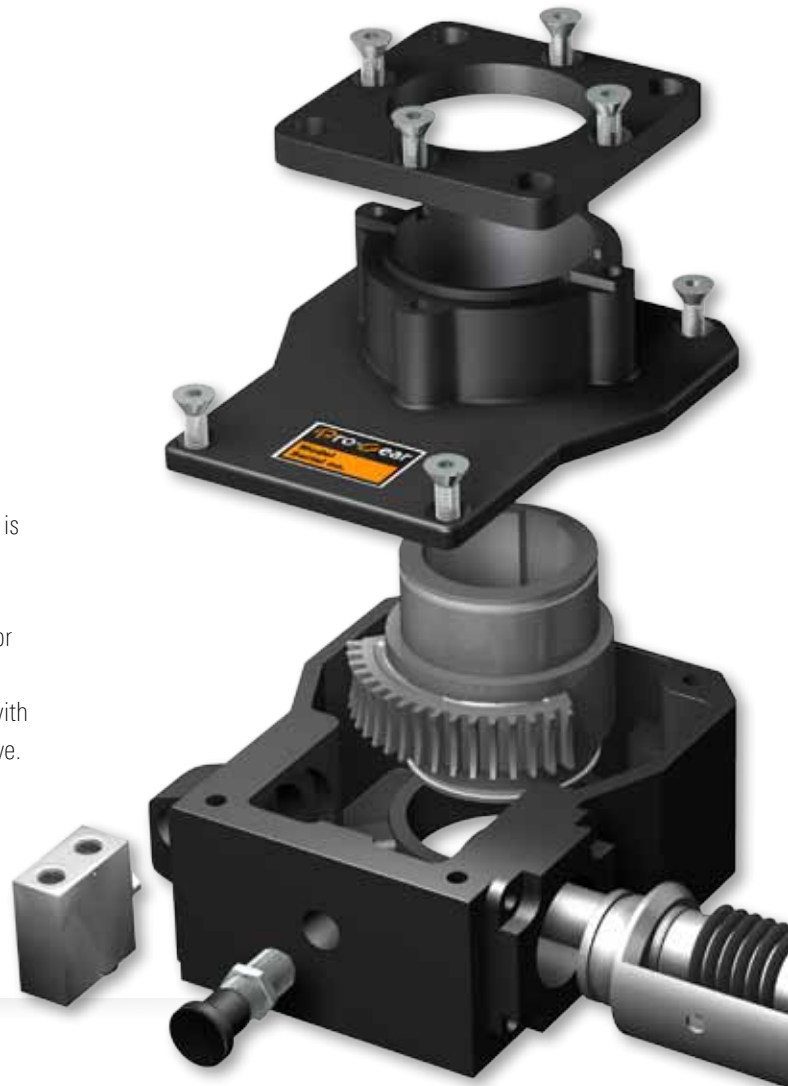

PERFORMANCE SPECIFICATIONS

- > 6 Models
- > Up to 5.000 Nm. Torque range
- > - 5° to 95° stroke
- > IP68 sealing
- > -25 °C to +110 °C (-13 °F to +230 °F) temperature range

TYPE	RATIO	TORQUE (Nm)		M.A. ± 10%	WEIGHT (Kg) excl. insert & adaptor
		OUTPUT	INPUT		
MO-D 150	40 : 1	150	12.6	11.9	3.1
MO-D 350	44 : 1	350	31.25	11.2	6
MO-D 700	52 : 1	700	50	14.0	16.3
MO-D 1600	42 : 1	1600	125	12.8	25
MO-D 3000	72 : 1	3000	155	19.4	49.5
MO-D 5000	267 : 1	5000	95	52.6	56

1Nm=0,737562 lbf.ft. 1Nm=8,8507 lbf.ins. [Converting International Units to British Units]

FEATURES

- > Stainless Steel inputshaft
- > Stainless Steel fasteners
- > Standardised according DIN / ISO 5211
- > 5 Models up to 5.000 Nm. Output torque
- > Axial needle bearings
- > NBR 70 gasket material
- > Sealed coupling by NBR O-ring
- > Polyurethane coated finish
- > Insert bush system for flexibility and reduced lead times (interchangeable with O-series & X-series gearboxes)
- > Blind tapped PCD's



PARTS / MATERIALS LIST MO-D SERIES

PART NO	DESCRIPTION	MATERIAL	SPECS / STANDARD
1	Body	Cast-iron	GG25 / ASTM A48
2	Gasket	Nitrile	NBR 70° Shore
3	Coverplate	Ductile-iron	GGG40 / ASTM 356
4	Top Mounting Flange	Ductile-iron	GGG40 / ASTM 356
5	Quadrant	Ductile-iron	GGG40 / ASTM 356
6	Worm	Carbon steel	C45-K
7	Axial needle bearing		
8	Shaft	Stainless steel	
9	O-ring	Nitrile	NBR 70° Shore
10	Closing Plate Rack	Ductile-iron	GGG40 / ASTM 356
11	Grease	Complex EP-0	DIN KGOG0.5N-30 ISO-LXCDIB0.5
12	Excentric Rack	Ductile-iron	GGG40 / ASTM 356
13	Fixating bolt	Stainless steel	
14	Excentric Lever	AISI-316 / Plastic	
	Fasteners	Steel 8.8	

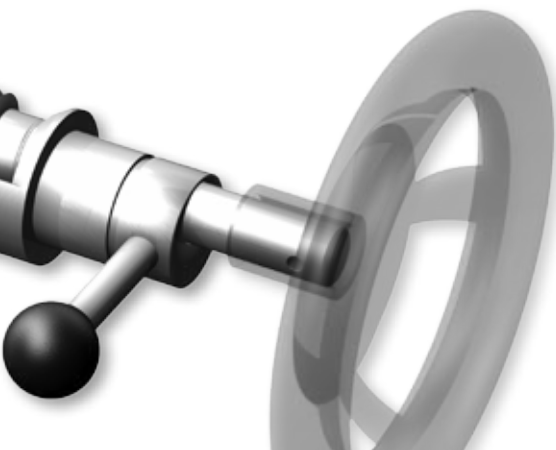
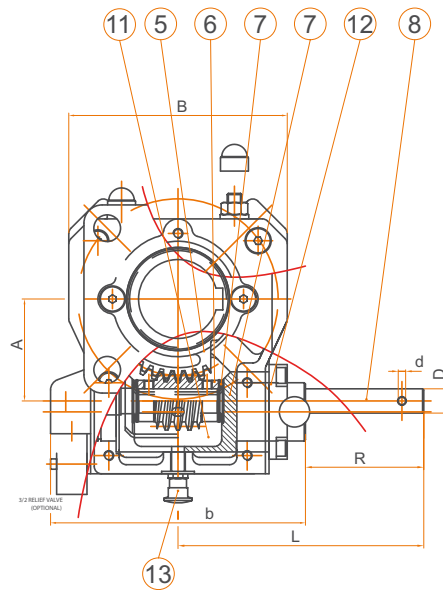
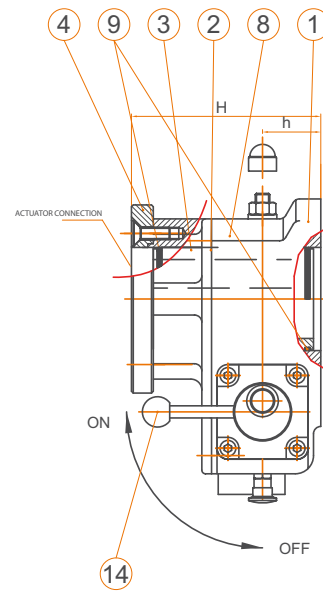

GEARBOX	TYPE	A	b	B	d	D	h	H	L	R	VALVE CONNECTION ACC ISO 5211			ACTUATOR CONNECTION ACC ISO 5211			
MO-D 150	MM	43.5	122.5	84	4	12	28.5	102	117.5	60	42 (F04)	50 (F05)	70 (F07)	50 (F05)	70 (F07)		
	INCH	1.71	4.82	3.31	0.16	0.47	1.12	4.02	4.63	2.36	1.65	1.97	2.76	1.97	2.76		
MO-D 350	MM	52.5	143.5	112	4	12	34	122	148	78	70 (F07)	102 (F10)		70 (F07)	102 (F10)		
	INCH	2.07	5.65	4.41	0.16	0.47	1.34	4.80	5.83	3.07	2.76	4.02		2.76	4.02		
MO-D 700	MM	68.75	168	135	5	15	41	130	161	78	70 (F07)	102 (F10)	125 (F12)	102 (F10)	125 (F12)		
	INCH	2.71	6.61	5.31	0.20	0.59	1.61	5.12	6.34	3.07	2.76	4.02	4.92	4.02	4.92		
MO-D 1600	MM	84	210	180	6.1	20	43	156	202.5	97.5	102 (F10)	125 (F12)	140 (F14)	125 (F12)	140 (F14)	165 (F16)	
	INCH	3.31	8.27	7.09	0.24	0.79	1.69	6.14	7.97	3.84	4.02	4.92	5.51	4.92	5.51	6.50	
MO-D 3000	MM	132.5	280.5	282	6.1	20	56.5	201	250.5	105	165 (F16)	254 (F25)		140 (F14)	165 (F16)	254 (F25)	
	INCH	5.22	11.04	11.10	0.24	0.79	2.22	7.91	9.86	4.13	6.50	10.00		5.51	6.50	10.00	
MO-D 5000	MM	132.5	395.5	282	6.1	20	56.5	201	372.5	110	165 (F16)	254 (F25)		140 (F14)	165 (F16)	254 (F25)	298 (F30)
	INCH	5.22	15.57	11.10	0.24	0.79	2.22	7.91	14.67	4.33	6.50	10.00		5.51	6.50	10.00	11.73



MO-D SERIES

HANDWHEELS "P(PRESSED)-SERIES"

TYPE	D	H
P100	Ø 100	38
P125	Ø 125	42
P160	Ø 160	48
P200	Ø 200	53

Dimensions mentioned in mm.

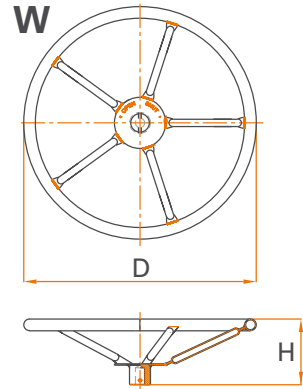
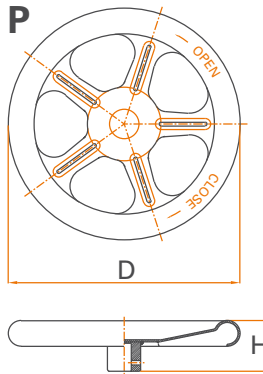

HANDWHEELS "W(ELDED)-SERIES"

TYPE	D	H
W125	Ø 125	50.5
W160	Ø 160	56
W200	Ø 200	67.5
W250	Ø 250	73
W300	Ø 300	102
W400	Ø 400	122
W500	Ø 500	141
W600	Ø 600	157
W700	Ø 700	180

Dimensions mentioned in mm.

How to size the diameter of the handwheel:

- 1 Get the output torque required

$$\text{Handwheel diameter} = \left(\frac{\text{Output Required}}{\text{M.A.}} \right) \times 5^*$$

- 2 Select the Handwheel diameter

* RIM pull 400 Nm

THE POWER IS YOURS!

Pro-Gear GmbH is a young, highly flexible team, who are carrying out every element of design, assembly and quality control with the utmost care.

The unique combination of the products, together with the know how and assembling facilities are creating for clients a relationship, unique in the valve actuator industries.



GOST certificated



Kopenhagener Straße 21
 D-48455 Bad Bentheim - Gildehaus
 Tel +49 (0)5924 255 840 - Fax +49 (0)5924 255 841
 E-mail info@pro-gear.de - www.pro-gear.de

