

1. INTRODUCTION:

This instruction manual contains important information regarding the safety instructions, installation, operation, maintenance and storage of the "Guardbox" limit switch boxes.

The limit switch boxes may only be mounted, wired and installed by qualified and trained personnel. If you require any additional information or assistance, please contact the manufacturer or its representative. All contacts are listed in the footnote together with the QR code for an easy access to the complete product documentation. Please read these instructions carefully before proceeding with the limit switch box installation and save them for future reference.

2. PRODUCT DESCRIPTION:

Guardbox Limit switch boxes are electromechanical devices ideal for monitoring the remote operation of industrial valves in plants, designed and manufactured for demanding applications in extreme environments and where there are requested high standards for safety and reliability products. The Guardbox devices are used to control the position of the valve and provide high accuracy electrical feedback signal of valve status to plant control systems. Guardbox devices are equipped in standard configuration with a 3D high visibility position indicator that represent a true indication of valve position. The indicator is visible on all 4 sides and is fully adjustable on 360° without disassembly. Guardbox limit switch boxes are built to be installed on valves or actuators which drive the process valves from closed to open position (Normal acting) or from open to closed position (Reverse acting) . *Normal acting* is considered full CW when the process valve is closed and CCW when the process valve is open. *Reverse acting* is full CW when the process valve is open and CCW when the process valve is closed.

3. SAFETY INSTRUCTIONS:

Guardbox Limit switch boxes are electromechanical devices ideal for monitoring the remote operation of industrial valves in plants, designed and manufactured for demanding applications in extreme environments and where there are requested high standards for safety and reliability products. The Guardbox devices are used to control the position of the valve and provide high accuracy electrical feedback signal of valve status to plant control systems.

On the outside of the GP-series box cover there are two adhesive labels on which are marked all the information and references about the manufacturer, electrical and ambient range of use of the specific configuration, product identification, together with a QR code for a quick link and easy access to the product documentation including wiring diagram, drawings and datasheet:

GP – Equipment Marking

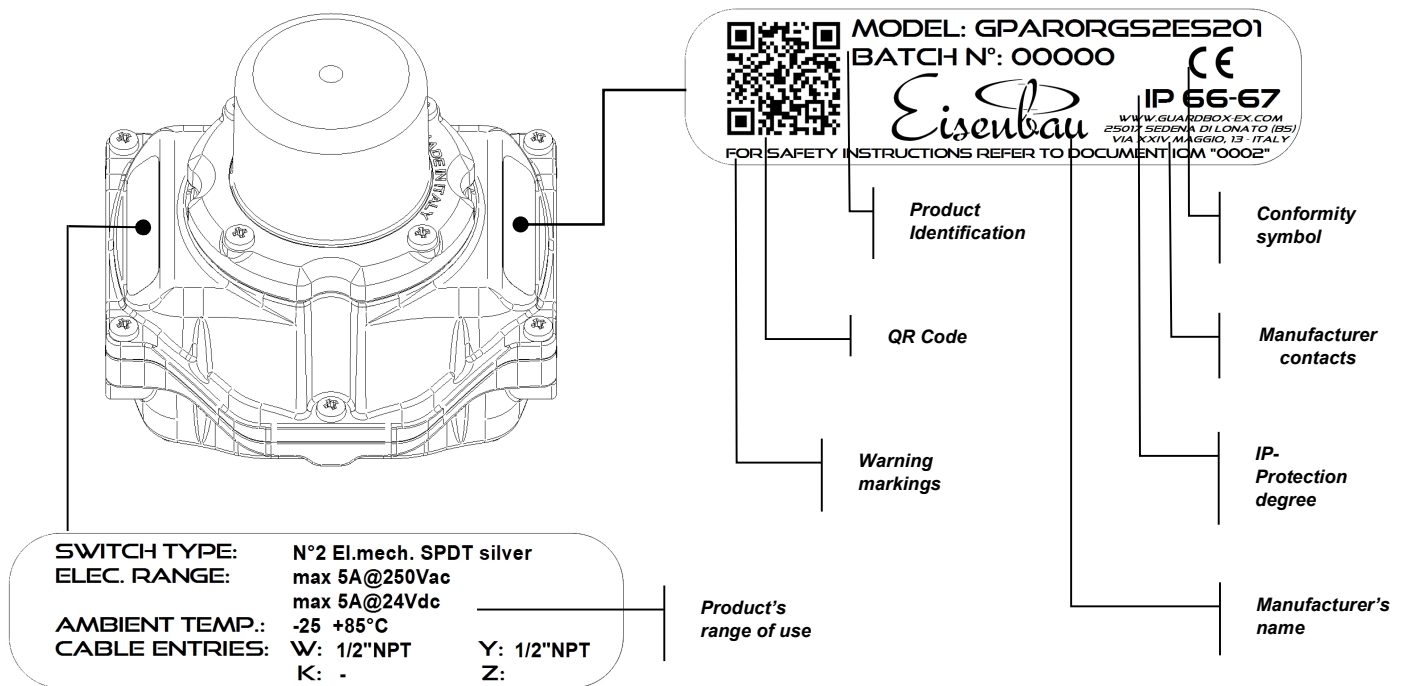



ENCLOSURE MATERIAL	
Aluminium Alloy EN AB ed AC 44300 Al Si 12 (Fe) (a) or Stainless steel 316L (CF3M)	



IOM (Installation, Operating & Maintenance Manual) 0002-ENG rev.4

It is the responsibility of the user to ensure that all the following safety instructions, essential health and safety requirements and warnings  are observed during installation, operation and maintenance of the product:

- 3.1 These instructions must carefully read before proceeding with the limit switch box installation and saved for future reference.
- 3.2 Installation should be carried out by suitably trained personnel.
- 3.3 If the box is integrated in a system or in a plant, the customer shall ensure that the local safety regulations are observed.
- 3.4 Before proceeding with the wiring, make sure that the characteristics of the electrical connection are compatible with electrical operation parameters of operation of the box.
- 3.5 Do not exceed the limit switch box performance limitation. Exceeding the limitation may cause damage to the limit switch, actuator and valve.
- 3.6 Use field wiring suitable to work at minimum and maximum ambient operating temperature indicated on the external nameplate of the box.
- 3.7 Operating the box over temperature limits will damage internal and external components.
- 3.8  **RISK OF SEVERE INJURIES!:** Do not open the box when energized.
- 3.9 Guardbox products are supplied with plastic caps fitted on the customer requested cable entries. Task of these caps is to protect the internal circuits of the products in the time between manufacturing and commissioning. It is responsibility of the installing personnel to replace the protective caps with suitably temperature rated cable glands.
- 3.10 Product IP rating is ensured only by the use of suitable IP rated cable glands and plugs.
- 3.11 Any unused cable entries must be sealed with suitably certified stopping plugs.
- 3.12 The box is provided with two grounding connection facilities, one inside and one outside the housing.
- 3.13 Both internal and external grounding connections are clearly identified and permanently marked on the box housing and are projected to facilitate the installation of the ground cable preventing it from rotating.
- 3.14 A grounding connection kit composed by n°2 phillips head screws plus n°2 toothed washers, is provided in a sealed bag, available inside the box. The two anti-vibration washers help to ensure the securing of the cable.
- 3.15  **CAUTION!:** The box can work in plants in presence of extreme environments and in contact with highly aggressive and corrosive substances that may affect the integrity of the product and its protection mode. To operate in such conditions the box is projected to be realized in different materials that ensure durability and reliability in operation. For the right choice of the available options, please contact Eisenbau.

4. DECLARATION OF CONFORMITY

The manufacturer Eisenbau s.r.l. herewith declare under his sole responsibility, that the limit switch boxes GP-series complies, when installed in accordance with the installation and safety instruction, with all the following norms:

1. Directive 2014/30/EU Electromagnetic compatibility directive (EMC)
EN 61326-2-3:2013 / A1:2009
2. Directive 2014/35/EU Low voltage directive (LVD)
EN 60947-5-1:2005

5. INSTALLATION

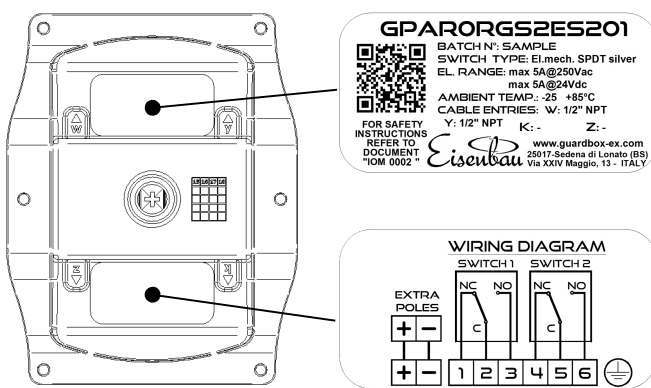

QR CODE OR DATA MATRIX TO DIRECTLY DOWNLOAD DRAWINGS, WIRING DIAGRAMS AND MANUALS DIRECTLY ON FIELD



6. MOUNTING

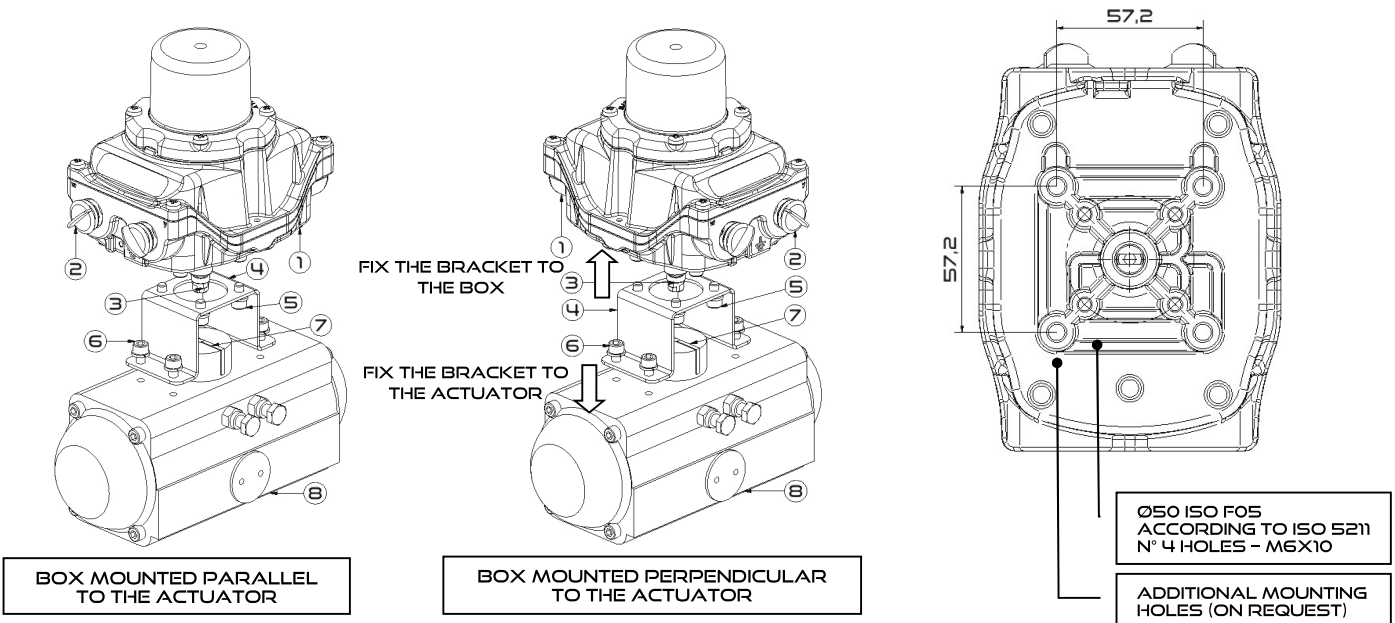

⚠ ATTENTION! : Consider the rotation direction of the actuator. The box is factory presetted to be installed parallel to CCW rotating actuators (Normal acting). For installation on reverse acting actuator or perpendicular to the actuator, the cams inside the box need to be reset before operating the system to avoid damages to the cams or to the sensors.

- 6.1 The box has on the bottom surface a drilling according to ISO 5211, as shown in the image. Fix the proper mounting bracket (supplied in option by Eisenbau) to the box using M6 screws (6).
- 6.2 Move the actuator to a completely "Open" or "Close" position, then align the box shaft (3) to actuator slot (7) ensuring of their correct coupling.
- 6.3 The box is designed, assembled and controlled to ensure a maximum operating torque, at the shaft, lower than 0,5Nm. An excessive misalignment of the two shafts during coupling, may result in the increase of this torque value until reaching the complete seizure of the shaft in the worst cases. Eccentricity between the two shafts must not exceed 0.2 mm.
- 6.4 The motion transmission from the actuator or valve to the box GP is attained by a mechanical coupling. Before installation on a valve or an actuator, make sure that the orientation of the position indicator is correct.
- 6.5 Operate the actuator before making the electrical wiring to ensure proper alignment between box and actuator . If it should be necessary, re-align box by loosening mounting bolts (6) and retighten bolts to the actuator (8) according to the required direction of rotation when satisfied with alignment.
- 6.6 Replace the protective caps with suitably temperature rated cable glands.



IOM (Installation, Operating & Maintenance Manual) 0002-ENG rev.4

7. ELECTRICAL WIRING:

⚠ CAUTION! : The electric components inside the box may carry dangerous voltage. The box must not be electrically connected during installation.

Follow switch adjustment, wiring instructions (if present) and indicator setting before servicing the limit switch box. Make sure that the characteristics of the electrical connection are compatible with electrical parameters of operation of the limit switch box. Do not exceed the limit switch performance limitation. Exceeding the limitation may cause damage to the limit switch, actuator and valve. Connect earth conductor.

⚠ ATTENTION! : the minimum clearance required to remove the box cover is 60mm.

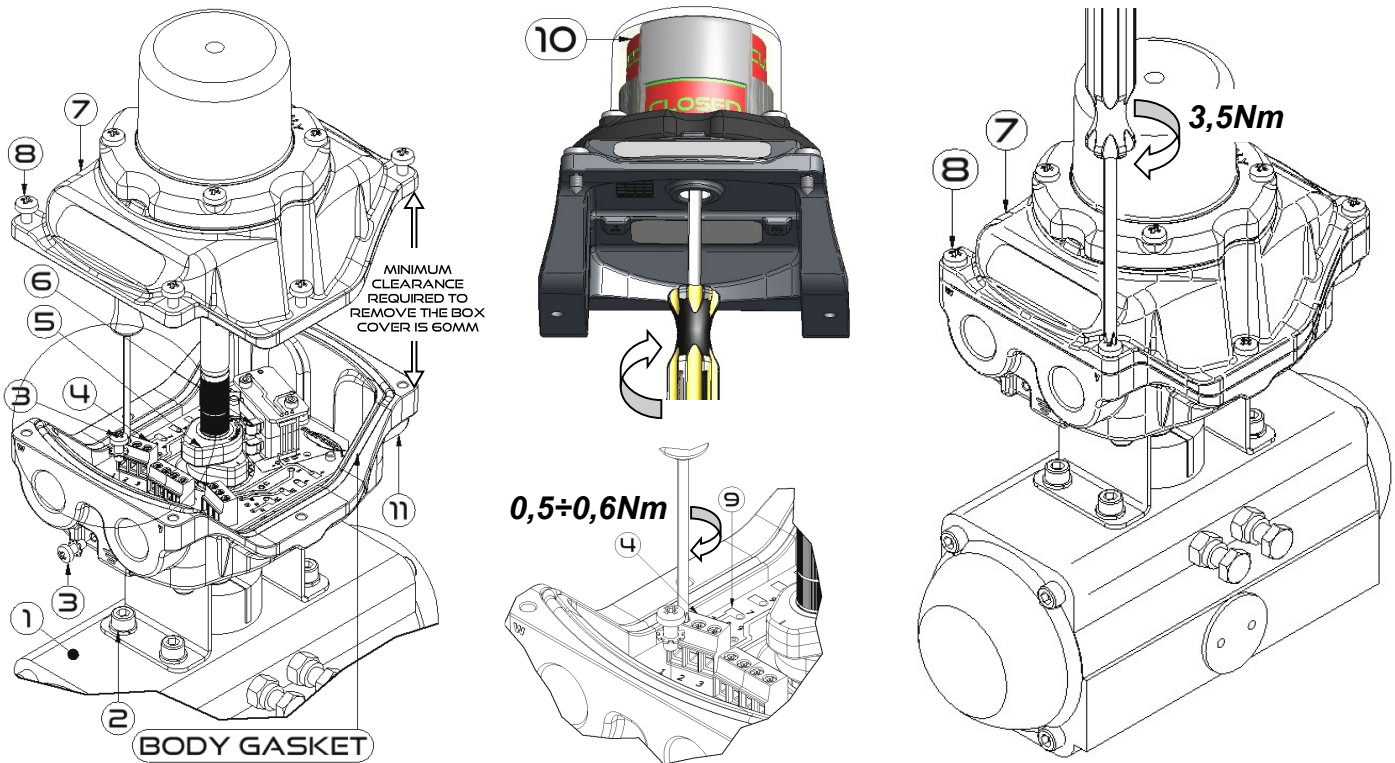

- 7.1 Replace the protective caps with suitably temperature rated cable glands
- 7.2 Product IP rating is ensured only by the use of suitable IP rated cable glands and plugs
- 7.3 Make sure that the cable glands are steadily tightened so that the sealing ring reaches the proper compression to avoid the transmission of mechanical stresses to the terminals (4).
- 7.4 Number, position and size of the provided cable entries are specified in the adhesive label outside the box cover. Number and type of cable entries can also be determined by reference to the 4th digit of limit switch box model marked on both internal and external labels. The certified cable entry options in the following table (1):

Table 1 – Cable entry options

ENTRY SIZE				MAX QUANTITY *
M20x1,5	M25x1,5	1/2"NPT	3/4"NPT	N°4
Metric thread conform to UNI 5870:1971 NPT thread conform to ANSI/ASME B1.20.1:1983				

* Every box housing can be customized with a various combination, in quantity and size, of cable entries up to a maximum of 4, depending on customer request

- 7.5 Unscrew the six box cover captive screws (8), then remove the box cover (7).
- 7.6 Connect field wiring to the terminals (4) within the circuit board (9) according to the wiring diagram and terminal labelling available inside the box.
- 7.7 Make sure that the electrical wires are steadily tightened and totally inserted into the terminals (4) and that there isn't non-insulated conductor material.
- 7.8 For box with circuit board (9) installed, the terminals (4) must be tightened using a torque value between 0,5±0,6Nm
- 7.9 Make sure that the box is connected to the ground with the proper screw (3) using a ground cable with a suitable section
- 7.10 For switch adjustment and cams (5) setting, please refer to following section (8. SWITCH AND CAM SETTING).
- 7.11 Check the cams (5) position before replacing the box cover (7).



IOM (Installation, Operating & Maintenance Manual) 0002-ENG rev.4

7.12  **ATTENTION!** : During the steps of removal and adjustment it is possible that the body gasket moves from its operating position. Verify that it is in the seat during assembly because the incorrect positioning of the gasket may cause malfunctions in the box.

7.13 Replace the cover (7) making sure that the orientation of the position indicator (10) is correct. If the cover (7) is hard to engage on the box shaft, the indicator (10) could have moved during box cover's opening. Use a phillips screwdriver to match the 3D indicator slot with the box shaft, than reassemble the cover (7).

7.14 Fasten the six captive screws (8) using a torque of 3,5Nm.

8. SWITCH AND CAM SETTING:

 **NOTE !:** Cams are factory presetted in order to operate in a box installed parallel (See section **6. MOUNTING**) to CCW rotating actuators (Normal acting). The lower cam (1) is regulated to operate the switch in the full CW position, when the process valve is **CLOSED**. The cam above (2) is regulated to operate the switch in the full CCW position, when the process valve is **OPEN**. All installation are suitably accompanied by dedicated instructions, due to the size of the installed sensor, cams may have the opposite regulation. Some applications moreover require the use of additional or special cams. These cams, placed above the cam (2), can be set for signaling intermediate positions or as a redundant signaling of valve **OPEN** or **CLOSED**. Where necessary, will be provided dedicated additional instructions for the proper setting of the special cams or electrical components. Following table represents the main cam configurations divided by specific type of switch, for applications not represented below, please refer to additional instructions provided inside the box packaging:

CAM EASY ADJUSTABLE REGULATING SYSTEM

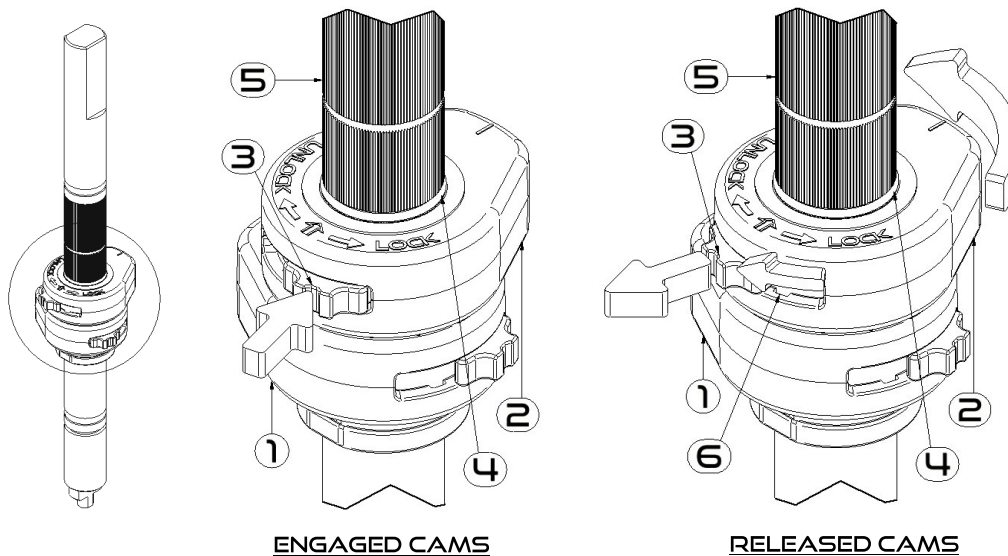

NO TOOL IS REQUIRED FOR THE REGULATION OF THE CAMS.

- Push the button (3) with the finger up to disengage the cam from its retaining seat (6), rotate CW the button until it stops, then release. Now the cam is free to rotate on the shaft (5). Retaining spring (4) prevent the cams to lift up during regulation.
- Rotate the cam till reaching the correct operating point
- Push the button (3) with the finger up to disengage the cam from its retaining seat (6), rotate CCW the button until it stops, then release. Now the cam is set and locked on the shaft (5).

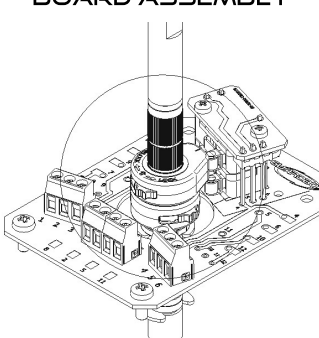
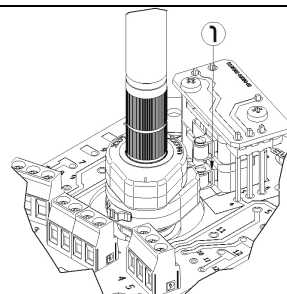
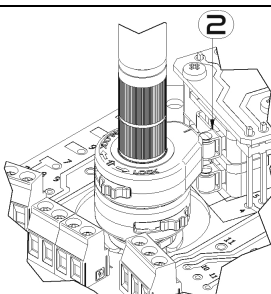
<p>ES / ED (ELECTROMECHANICAL SPDT/DPDT)</p>	<p>BOARD ASSEMBLY</p> 	 <p>TURN THE ACTUATOR PINION FULL CW AND REGULATE THE CAM TILL THE SWITCH (1) IS ACTIVATED</p>	 <p>TURN THE ACTUATOR PINION FULL CCW AND REGULATE THE CAM TILL THE SWITCH (2) IS ACTIVATED</p>
---	--	--	--



GUARDBOX - GP SERIES

IOM (Installation, Operating & Maintenance Manual) 0002-ENG rev.4

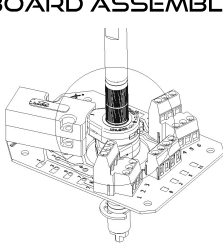
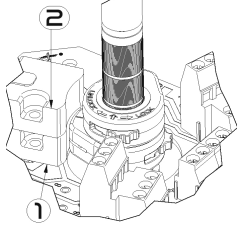
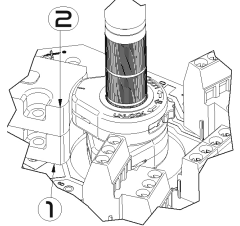
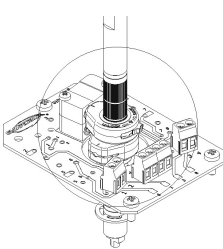
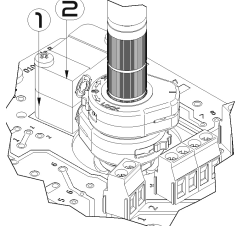
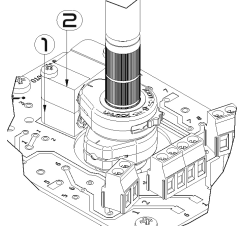
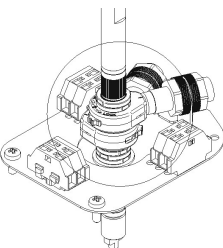
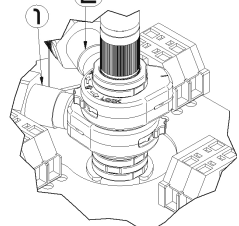
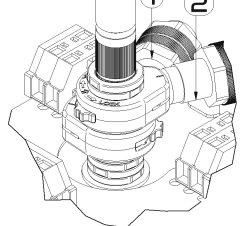
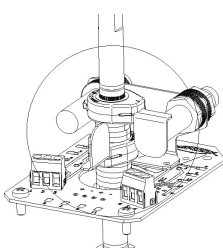
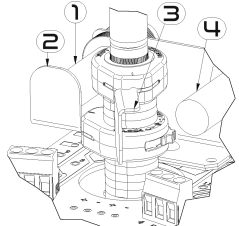
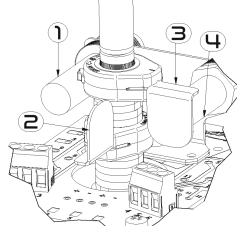
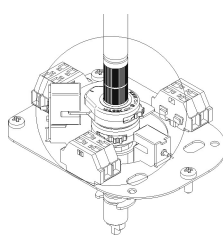
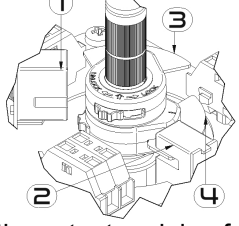
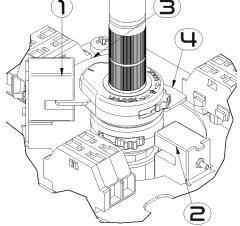
<p>MS / MD (MAGNETIC PROXIMITY SPDT/DPDT)</p>	<p>BOARD ASSEMBLY</p> 	 <p>Turn the actuator pinion full CW and regulate the cam till the switch (1) is activated</p>	 <p>Turn the actuator pinion full CCW and regulate the cam till the switch (2) is activated</p>
	<p>BOARD ASSEMBLY</p> 	 <p>Turn the actuator pinion full CW and regulate the cam till the switch (1) is activated</p>	 <p>Turn the actuator pinion full CCW and regulate the cam till the switch (2) is activated</p>
<p>PI / PN (INDUCTIVE PROXIMITY) / (INDUCTIVE PROXIMITY NAMUR)</p>		 <p>Turn the actuator pinion full CW and regulate the cam till the switch (1) is activated</p>	 <p>Turn the actuator pinion full CCW and regulate the cam till the switch (2) is activated</p>
		 <p>Turn the actuator pinion full CW and regulate the cam till the switch (1) is activated</p>	 <p>Turn the actuator pinion full CCW and regulate the cam till the switch (4) is activated</p>
		 <p>Turn the actuator pinion full CW and regulate the cam till the switch (1) is activated</p>	 <p>Turn the actuator pinion full CCW and regulate the cam till the switch (2) is activated</p>



9. INDICATOR SETTING:

- 9.1 The 3D indicator (2) is visible on all 4 sides and is fully adjustable on 360° without disassembly.
- 9.2 Loosen indicator M5 captive screws and rotate transparent indicator dome (1) to desired viewing angle according to valve position. (OPEN or CLOSED appearing through indicator window).
- 9.3 Retighten the four captive M5 screws (3) using a torque of max **3,5Nm** for standard plastic dome while, for glass dome version, do not exceed the max torque of **0,5Nm**.

STANDARD PLASTIC DOME

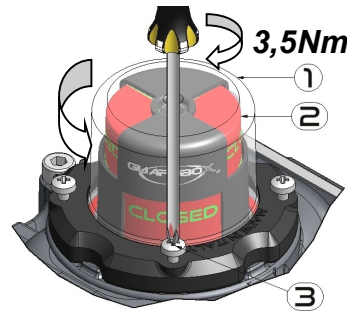

OPTIONAL GLASS DOME

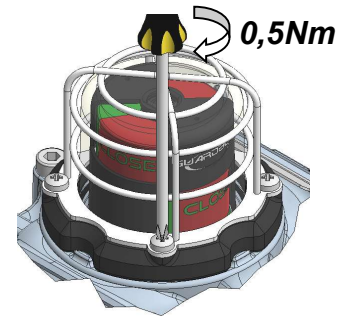

10. STORAGE AND MAINTENANCE:

- 10.1 Store the boxes away from UV rays and atmospheric agents, in an environment with temperature between 0°C and 40°C.
- 10.2 The Guardbox devices require no servicing during normal working life if properly installed, except the normal inspection of mounting screws/bolts, O-rings and terminal wiring for signs of loosening or corrosion as part of the routine plant maintenance.
- 10.3 Guardbox boxes have been projected to withstand the most severe mechanical fatigue test (more than 1000000 cycles) and accelerated corrosion test (up to 500 hours according to UNI EN ISO9227). However for long-time outdoor usage especially in aggressive environments or if subjected to an elevate number of operations, is recommended to periodically check the correct functionality and integrity of the box. If some parts are damaged, please contact the manufacturer or the local distributor for certified replacement parts.
- 10.4 Maintenance should be carried out by suitably trained personnel.
- 10.5 Ensure safety warnings  are observed during maintenance.
- 10.6 Eisenbau reserves the right to change or modify products without prior notice or without incurring any obligation to make some changes on products previously or subsequently sold.
- 10.7 All trademarks are property of their respective owners.

11. WARRANTY:

For warranty conditions, please refers to section 7 of document "General terms and condition of sale".



