

Installation and Operation

Pneumatic Positioner F10

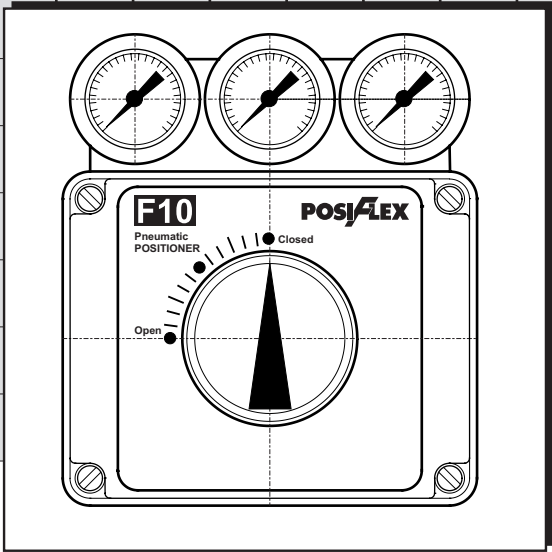
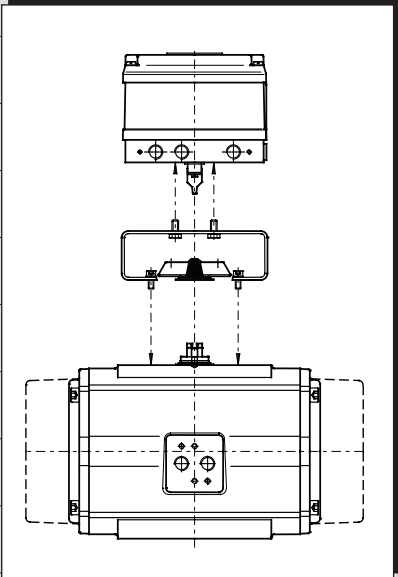
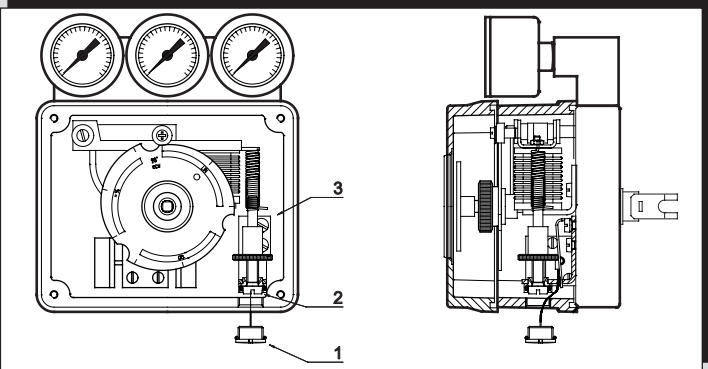
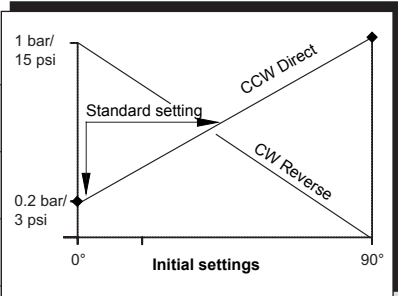

CONTENTS

Product Description	3
Operating Principles	4
Installation Rotary Actuators	5
- Mechanical installation - Rotary actuators	5
- Pneumatic Connections - Double acting	5
- Pneumatic Connections - Single acting	6
- CAUTION!: Air Supply Requirements	6
Calibration - Initial Settings - Cam Changes	7
- Initial Settings	7
- Cam Changes	7
- Zero Adjustment	8
- Range Adjustment	8
Maintenance	9
- Troubleshooting	9

General Specifications:

	Metric	Imperial
Hysteresis:	0.6%	
Linearity:	1.0%	
Air Flow:	210 NI/min (at 6 bar)	7.4 SCFM (at 87 psi)
Air Consumption:	15 NI/min (at 6 bar)	0.6 SCFM (at 87 psi)
Min. volume actuator:	0.1 NI	6.1 in ³
Temperature:	-20° to +80°C	-4° to +176°F
Enclosure:	IP65	NEMA 4
Mounting:	VDI/VDE 3845	
Air Entry:	G 1/4"	1/4" NPT
Air Supply:	1.4 to 8.6 bar	21 to 125 psi

Input Signal

- Standard:	0.2 to 1.0 bar	3 to 15 psi
- Inst Adjustable elbaar:	0.2 to 0.6 bar	3 to 9 psi
	0.6 to 1.0 bar	9 to 15 psi

Media

Non-lubricated instrument air, filtered at 25 micron.

Dew point should be 10°C (18°F) below enviromental temperatur.

Air quality class 3-2-3 accord. to ISO 8573-1.

Product Description

The F10 positioner provides the means for a pneumatic actuator to be positioned to any point between full open and full closed position. This allows accurate setting of rotary and linear control valves as well as a wide range of dampers and similar devices. The actuator’s movement is controlled in proportion to a 0.2 to 1 bar (3-15 psi) incoming pressure signal.

The Posiflex F10 positioner provides:

- **High positioning speed** for small and larger actuators
- **One single model** covers both single acting and double acting actuators.
- **External Zero Adjustment.**
- **High accuracy** due to “high gain” amplification.
- **Range adjustment** with split range function. A special came is available for the split range function on rotating actuators.

- **Three Position Cam** for Rotary Actuators provides for linear, quick opening and equal percentage characteristics. A special cam for rotary actuator provides for split range.
- **Direct or Reverse Acting.**

F 10 positioners are available for both rotary and linear applications and because of the standardized mounting interface (VDI/VDE 3845 or IEC 534/ 6), installation is simple and trouble free. Mounting kits are available for most actuator types.

The purely Pneumatic mode of operation means that F10 positioners may be used in explosion hazardous areas without any additional protection being necessary.

A wide range of modular control options are available: These cover the addition of gauges, indicating switches, position transmitters, etc.

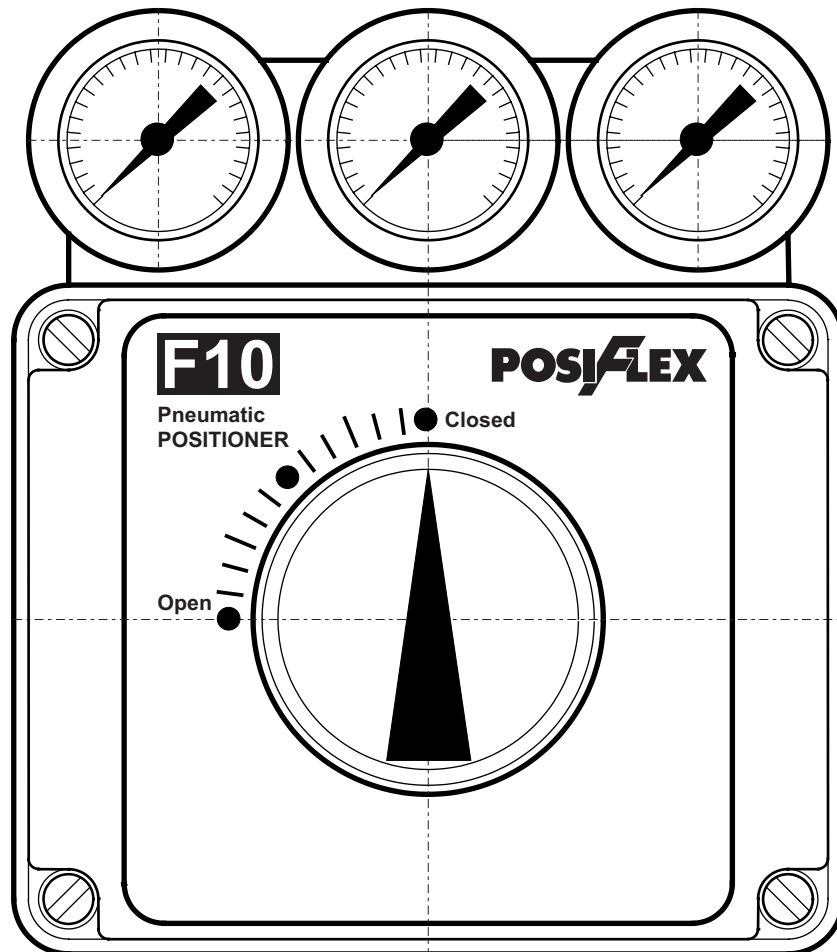

Operating Principles

The Posiflex F10 Pneumatic Positioner is a high gain, motion balance instrument, suitable for use with a wide variety of single acting and double acting rotary and linear actuators.

Referring to the diagram below: The positioner is shown in a mid position with INSTRUMENT and SUPPLY air connected. The flapper and nozzle (5) maintains the instrument in its "balanced" state with just enough pilot air pressure being applied to the spool valve for it to hold the actuator in its "set" position.

When the actuator is required to move to a new "more open" position, the INSTRUMENT pressure signal is increased accordingly. This closes the air gap at the nozzle (5) causing an amplified pressure increase at the spool valve end, this in turn displaces the spool and allowing

an increasing air pressure at the "open" side of the actuator and exhausting air from the "close" side. When the actuator moves position it rotates the cam (6) in a CCW (counter clockwise) direction and in doing so it progressively opens the air gap at the nozzle (5). On reaching the new set point the pilot pressure is reduced to the "balanced" state and again locks the actuator in new set position.

Similarly a decreasing INSTRUMENT pressure will cause a CW (clockwise) positioner movement.

The operation for single acting actuators is the same except that the unused pneumatic connection OUTPUT 2 is plugged off.

- 1. Balance assembly.
- 2. Pneumatic valve block.
- 3. Actuator.
- 4. Mechanical feedback.
- 5. Flapper and nozzle.

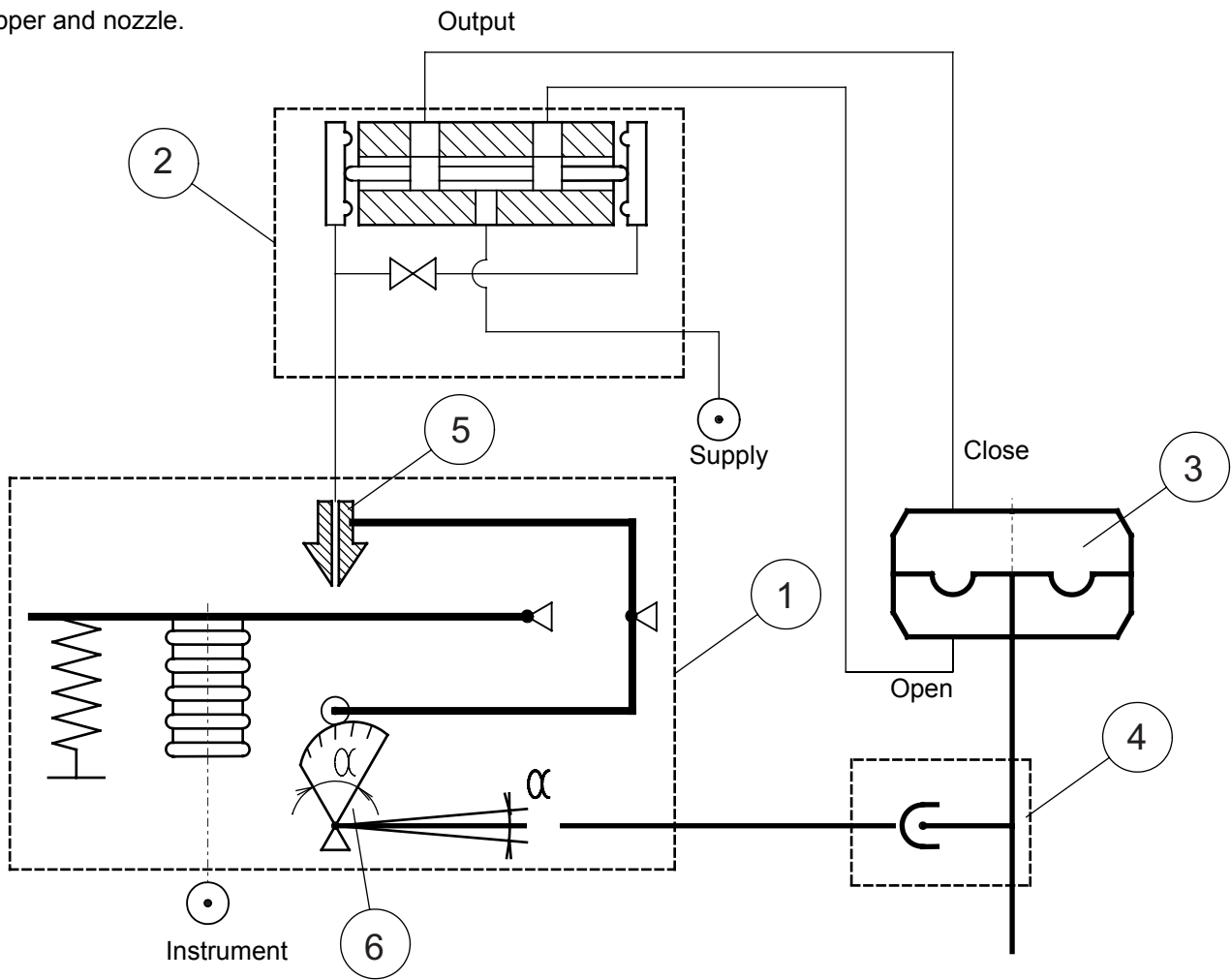

Installation Rotary Actuators

Mechanical installation - Rotary actuators

The positioner is mounted on to the top surface of the pneumatic actuator using an appropriate mounting kit. The positioner's mounting configuration is to the VDE/VDI 3845 standard, if the actuator is to the same standard, a standard NAMUR mounting kit can be used, otherwise a special mounting kit will have to be obtained.

Assuming the installation will use the standard NAMUR mounting kit, proceed as follows:

1. Fix the bracket to the top surface of the actuator using the 4 screws provided.
2. Check that the spring clip is securely in place on the bottom of the positioner shaft.
3. Locate the positioner in place on top of the bracket, making sure that the 4 mm. tongue locates properly into it's slot in the actuator spindle and the centring screw is in position.
4. Fix the positioner to the bracket using the 4 screws provided.

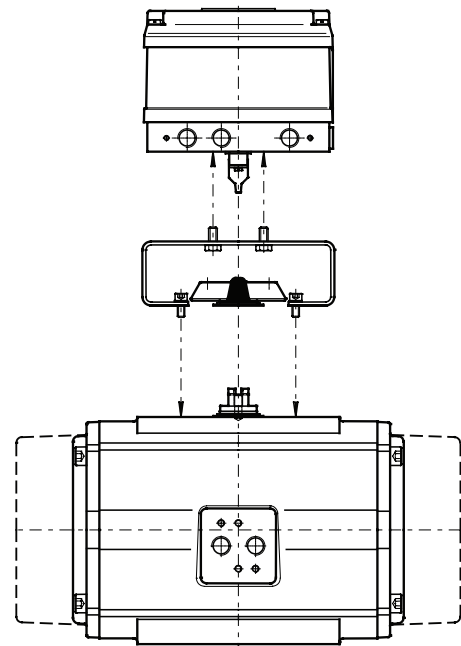

Mechanische Montage

Pneumatic Connections - Double acting

This assumes a standard (direct acting) installation with an increasing signal to open the valve in a CCW (counter clockwise) direction.

Before connecting any air supply make sure that the air available is clean dry instrument air filtered to at least 25 microns - see page 4.

1. Connect an appropriate piece of air tubing between the port 1. on the positioner to the "A" port on the actuator. (The "A" port is the one that when air is applied to it, rotates the actuator in a counter clockwise direction).
2. Connect an appropriate piece of air tubing between the port 2. on the positioner to the "B" port on the actuator. (The "B" port is the one that when air is applied to it, rotates the actuator in a clockwise direction).
3. Connect an air supply to the positioner port Marked "Supply".
4. If the positioner is required to meet enclosure rating IP54, be sure that the «Exhaust» port is connected with elements which prevent the input of water and give no pressure rising inside the housing because of throttling of exhaust flow (no sintered filters, but a piece of tube or a special IP65 Exhaust plug with diaphragm).
5. Connect the instrument air to the port marked «INSTR».

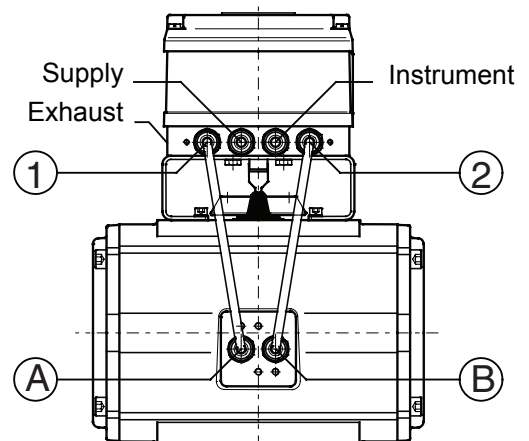

Pneumatic connections

Double acting

Note: For a reverse acting assembly, both the air connections and the cam plate must be reversed - see page 7.

Pneumatic Connections - Single acting

This assumes a standard installation, direct acting with an increasing signal to open the valve in a CCW (counterclockwise) direction.

Before connecting any air supply make sure that the air available is clean dry instrument air filtered to at least 25 microns - see below.

1. Connect an appropriate piece of air tubing between the port 1. on the positioner to the "A" port on the actuator. (The "A" port is the one that, when air is applied to it, rotates the actuator in a counter clockwise direction).
2. Connect an air supply to the positioner port marked "Supply".
3. The unused positioner port 2, should be plugged using the pipe plug supplied with your positioner. Connect port «Exhaust» with elements, which guarantee IP54.
4. If the positioner is required to meet enclosure rating IP54, be sure that the «Exhaust» port is connected with elements which prevent the input of water and give no pressure rising inside the housing because of throttling of exhaust flow (no sintered filters, but a piece of tube or a special IP65 Exhaust plug with diaphragm).
5. Connect the instrument air to the port marked «INSTR».

Note: For a reverse acting assembly, use the same procedure but remember that a reverse acting actuator must be used - see page 7.

CAUTION!: Air Supply Requirements

Pressure in excess of 8.6 bar (125 psi) will cause damage to the Positioner. Positioner supply air must be clean, dry and oil free.

The air should be filtered to at least 25 microns (as defined in the Instrument Society of America standard ISA S7.3 specifications). The filter should be installed as close to the positioner as possible to ensure maximum efficiency.

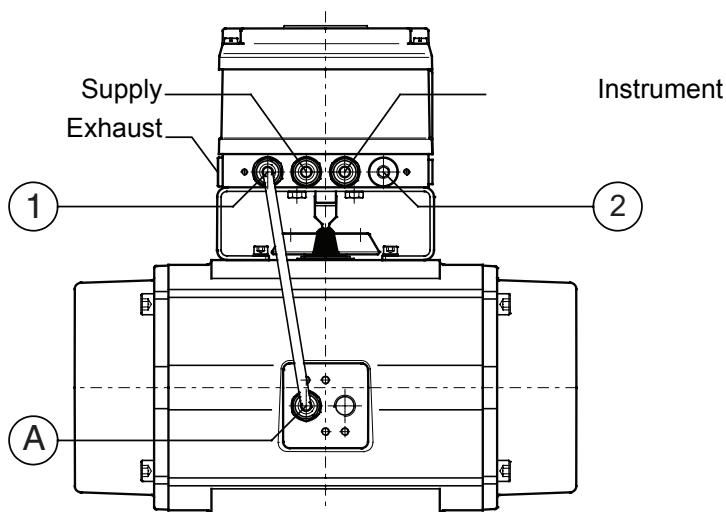

Pneumatic Connections
Single acting

Calibration - Initial Settings - Cam Changes

Initial Settings

The factory settings provide the positioner with an initial range of settings that will allow the operation of positioners on most applications.

Signal Input -0.2 to 1.0. bar. (3-15 psi).

Range -0% to 100%

Control Function -Linear.

Action -Direct Acting.

(Opening on increasing Signal in

CCW-direction).

The F10 positioner is provided with the following features for making changes to the initial settings:

Zero By the external zero adjustment screw. Range By the internal range adjustment ring. Range Spring The standard range spring is suitable for

normal operation and split ranging. Cam Segment Six segments are provided for the rotary positioner and eight segments for the linear positioner (see table).

Cam Changes

Remove the cover and indicator from the positioner exposing the Cam. The Cam is double sided: CCW for direct acting, CW for reverse acting.

If the actuator is fully clockwise and the actuator is to rotate CCW on instrument signal increase, the Cam should be on the "CCW" side and the start marking should be in line with the Cam Follower Bearing. If the actuator is fully counterclockwise and the actuator is to rotate CW on instrument signal increase, the Cam should be on the "CW" side and the start marking should be in line with the Cam Follower Bearing.

If the cam is not in the correct position, change as follows:

1. Remove the cam nut (1).
2. Re-install the cam plate in the correct position, taking care that the correct segment is adjacent to the cam follower (2).
3. Replace the cam nut and fix it.
4. Replace the indicator disk, taking care that it is in the correct position.

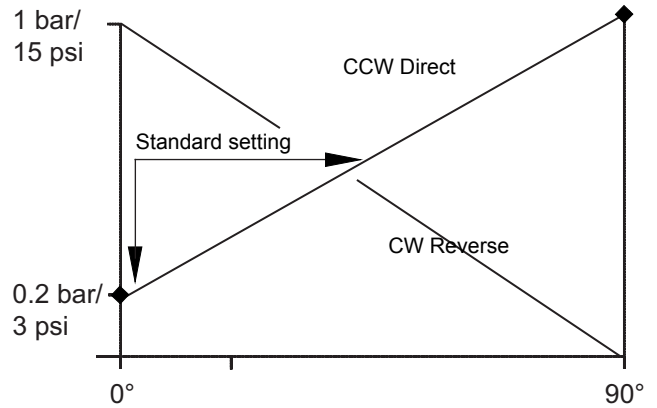

Initial settings

Cam Segment Rotary actuator	
90° CCW	90° CW
lin	lin
=%	=%
QO	QO
*	*

lin = linear

=% = equal percentage

QO = Quick Opening

* = Special cam split range

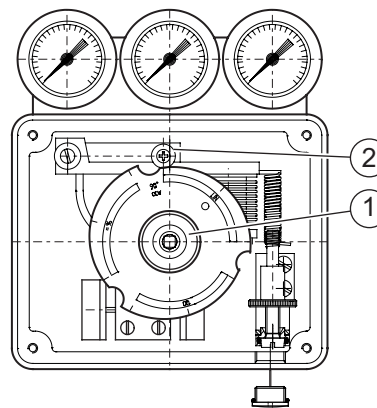

Top view of cam

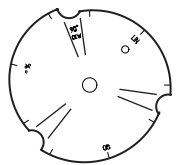

Cam 90°

Before making any adjustments positioner should be properly mounted, the cam should be in the correct sector on the correct side as determined from the cam markings.

Zero Adjustment

The zero adjustment is carried out externally, this is located at the right hand side of the positioner casing and is accessed by means of a removable plug.

1. Remove the access plug (1).
2. Adjust the instrument signal to its minimum value (0.2 bar for a 0.2-1.0 bar range), (3 psi for a 3-15 psi range).
3. Rotate the Zero adjusting screw (2) until the actuator just begins to move. Turning the adjusting nut clockwise raises the start value.
4. After adjustment, replace the access plug (1).

Range Adjustment

Remove the cover from the positioner exposing the knurled range adjuster ring, this is located at the righthand side of the assembly.

The factory set range is so that a 0.2 to 1.0 bar (315 psi) instrument pressure produces a full stroke movement. This may be changed by resetting the full stroke position (max. opening) at the 1.0 bar (max. instrument) pressure. To adjust the range carry out the following:

1. Increase the instrument signal to its maximum value (1.0 bar for a 0.2 to 1.0 bar range, 15 psi for a 3-15 psi range).
2. If the actuator does not reach its final position, rotate the knurled adjusting ring (3) in CCW-direction until the full stroke position is reached.
3. Turning the range screw cw reduces the range; ccw increases the range.
4. After range adjustment, reset the zero position and adjust it if necessary.

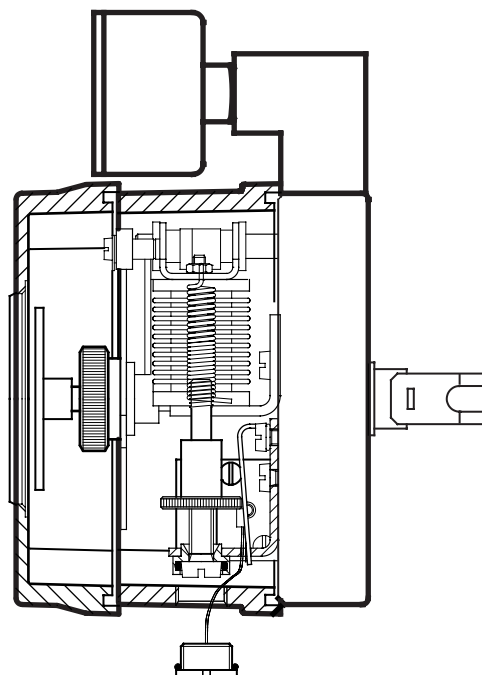
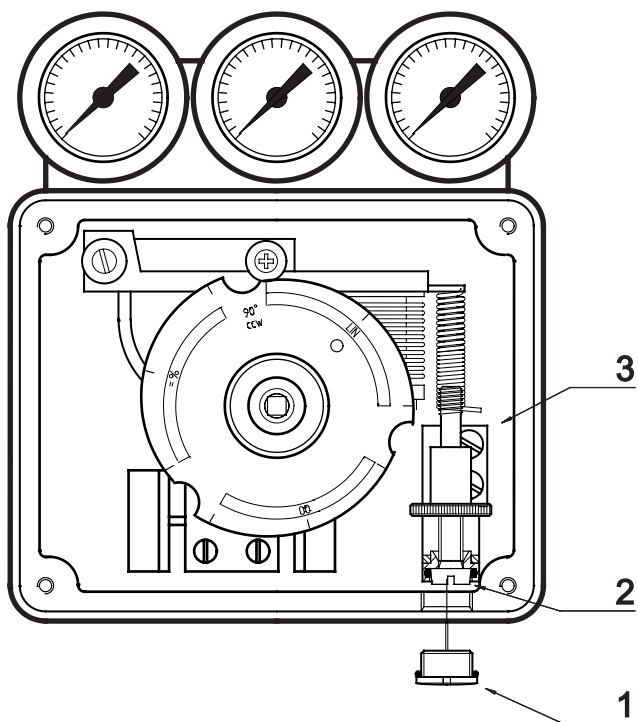

Maintenance

Troubleshooting

If it is suspected that the positioner is not operating correctly, check the following :

1. Is the Cam in the proper orientation for your application ? (See page 5).
2. Is the positioner properly mounted ? (See page 3).
3. Is the coupling or NAMUR shaft in proper alignment with the Positioner Cam shaft and actuator ?
4. Is the positioner piped correctly ? (See page 3 and 4).
5. Make sure supply pressure exceeds minimum pressure required to move the actuator.
6. Is there instrument and output pressure at the Positioner ? (If the Positioner is equipped with a Gauge Block, check the instrument and output pressure readings. If the positioner is not equipped with a Gauge Block, connect gauges to the instrument and output ports and note readings.)
7. Is the actuator working properly ? (Disconnect the supply pressure from the Positioner and connect the supply pressure to the actuator. Does the actuator move full stroke ?)

If additional help is needed, please contact your local EL-O-Matic office or representative.

World Area Configuration Centers (WACC) offer sales support, service, inventory and commissioning to our global customers. Choose the WACC or sales office nearest you:

NORTH & SOUTH AMERICA

19200 Northwest Freeway
Houston, TX 77065
T +1 281 477 4100
F +1 281 477 2809

P. O. Box 10305
Jubail 31961
Saudi Arabia
T +966 3 340 8650
F +966 3 340 8790

Av. Hollingsworth,
325, Iporanga Sorocaba,
SP 18087-105
Brazil
T +55 15 3238 3788
F +55 15 3228 3300

24 Angus Crescent
Longmeadow Business Estate
East P.O. Box 6908; Greenstone;
1616 Modderfontein, Extension 5
South Africa
T +27 11 451 3700
F +27 11 451 3800

ASIA PACIFIC

No. 9 Gul Road
#01-02 Singapore 629361
T +65 6501 4600
F +65 6268 0028

EUROPE

Berenyi u. 72- 100
Videoton Industry Park,
Building #230
Székesfehérvár 8000
Hungary
T +36 22 530 950
F +36 22 543 700

No.1 Lai Yuan Road
Wuqing Development Area
Tianjin 301700
P.R. China
T +86 22 8212 3300
F +86 22 8212 3308

MIDDLE EAST & AFRICA

P. O. Box 17033
Dubai
United Arab Emirates
T +971 4 811 8100
F +971 4 886 5465

www.emersonprocess.com/elomatic

All Rights Reserved.

We reserve the right to modify or improve the designs or specifications of the products mentioned in this manual at any time without notice. Emerson Process Management does not assume responsibility for the selection, use or maintenance of any product. Responsibility for proper selection, use and maintenance of any Emerson Process Management product remains solely with the purchaser.

©2016 Emerson Electric Co.

For complete list of sales and manufacturing sites, please visit www.emersonprocess.com/valveautomationlocations or contact us at info.valveautomation@emerson.com