



# Contents

<b>1</b>	<b>Important Safety Procedures .....</b>	<b>1</b>	<b>10</b>	<b>Assembly Instructions.....</b>	<b>6</b>
<b>2</b>	<b>ATEX instructions for use in (potential) explosive areas .....</b>	<b>2</b>	10.1	Pinion Assembly .....	6
2.1	Intended use.....	2	10.2	Alignment of pinion for correct piston assembly .....	6
2.2	Safety Instructions.....	2	10.3	Piston Assembly .....	6
2.3	Temperature range for (potential) explosive areas.....	2	10.3.1	Clockwise rotation .....	6
<b>3</b>	<b>Operating Media, Pressures and Temperatures .....</b>	<b>3</b>	10.3.2	Counter-Clockwise rotation .....	6
3.1	Operating media .....	3	10.4	Travel stop assembly.....	7
3.2	Operating Temperature range .....	3	10.5	End cap assembly on double acting actuators .....	7
<b>4</b>	<b>Actuator to Valve Installation.....</b>	<b>3</b>	10.6	Spring Return Actuators .....	7
4.1	Bi-directional Travel Stops .....	3	10.6.1	Spring set adjustments.....	7
4.2	Travel Stop Adjustments.....	3	10.6.2	Installing the Springs.....	8
<b>5</b>	<b>Piping Instructions.....</b>	<b>3</b>	<b>11</b>	<b>Testing the Hytork Actuator.....</b>	<b>8</b>
<b>6</b>	<b>Solenoid Valves on Spring Return Actuators .....</b>	<b>4</b>	11.1	Testing and Cycling of Infrequently Used or Stored Actuators .....	8
<b>7</b>	<b>Position Feedback.....</b>	<b>4</b>	<b>12</b>	<b>Retractor Rods .....</b>	<b>8</b>
<b>8</b>	<b>Spares Recommendations.....</b>	<b>4</b>	12.1	Spring Removal System Board.....	8
<b>9</b>	<b>Disassembly Procedure.....</b>	<b>4</b>	<b>13</b>	<b>Service.....</b>	<b>8</b>
9.1	End cap and springs disassembly on Spring Return actuators.....	4	<b>14</b>	<b>Grease Specification.....</b>	<b>8</b>
9.2	Changing spring sets on XL26 to XL681 .....	5	<b>15</b>	<b>Parts and Materials .....</b>	<b>9</b>
9.3	End cap disassembly on Double Acting actuators .....	5			
9.4	Piston disassembly .....	5			
9.5	Pinion disassembly .....	5			
9.6	Inspection.....	5			

# 1 Important Safety Procedures

**Table 1. Applicable Models**

XL 26	XL 281	XL 2586
XL 71	XL 426	XL 4581
XL 131	XL 681	
XL 186	XL 1127	
XL 221	XL 1372	

Hytork XL actuators are only intended for use in large-scale fixed installations excluded from the scope of Directive 2011/65/EU on the restriction of the use of certain hazardous substances in electrical and electronic equipment (RoHS 2).

Installation, adjustment, putting into service, use, assembly, disassembly and maintenance of the Actuator is strictly reserved to qualified personnel. Before installation, operation and maintenance, read the relevant sections of:

- This manual
- Quick Reference Guide: DOC.QRG.XL

## ⚠ CAUTION - BEFORE YOU START

- Always disconnect the Air and Electrical supplies before carrying out any form of maintenance on an Actuator.
- When removing any ball valve or plug valve assemblies from a pipe system, isolate the piping system on which the Actuator is installed and relieve any media pressure that may be trapped in the valve cavities before removing the Actuator for maintenance.
- Always contain the Spring tension with Hytork Retractor Rods as explained in Section 9 (Disassembly procedure). Follow instructions for using the Retractor Rod carefully. Only Hytork manufactured or approved Retractor Rods are to be used for Spring removal. As with any threaded tool that is frequently used Retractor Rods should be checked to ensure that the threads are not worn or damaged in any way and greased regularly. Any damaged or worn Rods must not be used and must be destroyed.
- Never attempt to 'BLOW OUT' the Pistons or the End caps from the Actuator Body by using air pressure.
- Never turn the stop screws completely out when the actuator is under pressure.

Numbers in brackets (#) refer to parts on the exploded view drawing (Chapter 15). All Hytork XL Spares Kits are supplied with SAFEKEY assemblies (13/14) cut to an exact length which will fit the circumference of the End Cap (21) when fully assembled into the Actuator. Any shortened SAFEKEY must not be used.

If in doubt contact Emerson or your local Hytork Stocking Distributor. Read the relevant sections carefully before continuing.

## IMPORTANT - STORAGE

- Failure to follow proper storage guidelines will void warranty.
- Warehouse storage: Hytork Actuators should be stored in a clean, dry warehouse, free from excessive vibration and rapid temperature changes. Actuators should not be stored on any floor surface.
- On site storage: Hytork actuators should be stored in a clean, dry warehouse, free from excessive vibration and rapid temperature changes. Prevent moisture or dirt entering the actuator. Plug or seal both air connection ports.

## ⚠ WARNING - LIFTING INSTRUCTIONS

- Use lifting equipment as required by national or local legislation.
- Use lifting straps to lift the assembly of actuator and valve.
- Do not attach lifting straps to only the actuator, to lift the assembly of actuator and valve.

**Table 2. Weight of Actuators**

Model	Double Acting		Spring Return with S80 Springs	
	Kg	Lbs	Kg	Lbs
XL26	1.39	3.06	1.53	3.37
XL71	2.39	5.27	2.78	6.13
XL131	3.90	8.60	4.76	10.49
XL186	4.77	10.52	5.45	12.02
XL221	6.19	13.65	7.76	17.11
XL281	7.02	15.47	9.90	21.83
XL426	7.30	16.10	12.50	27.56
XL681	8.80	19.40	22.50	49.60
XL1127	22.00	48.50	36.00	79.37
XL1372	27.00	59.52	46.60	102.73
XL2586	46.00	101.41	79.00	174.16
XL4581	83.00	182.98	142.00	313.05

## 2 ATEX instructions for use in (potential) explosive areas

### 2.1 Intended use

The Hytork XL series pneumatic actuators are a Group II category 2 equipment and intended for use in areas in which explosive atmospheres caused by mixtures of air and gases, vapours, mists or by air/dusts are likely to occur. Therefore it may be used in (ATEX) classified Zones 1, 2 (Gasses) and/or 21, 22 (Dust).

### 2.2 Safety Instructions

- a. Assembly, disassembly and maintenance, is only allowed at the actuator, when, at the time of the activity, there is not an explosive mixture.
- b. Prevent entry of explosive mixtures into the actuator. We suggest utilizing a solenoid with a “breather” function on spring return actuators when used in potentially explosive atmospheres.
- c. The plastic position indicator caps are approved for ATEX gas group IIB areas.
  - In areas where ATEX gas group IIC requirements apply, the plastic indicator for actuator sizes XL26 to 281 is approved for use.
  - In areas where ATEX gas group IIC requirements apply, do not use the plastic position indicator cap of sizes XL426 up to XL4581, to avoid build up of static electricity.
- d. In order to avoid increasing dust explosion risk, periodically clean dust deposits from all equipment.
- e. When equipment is installed in a hazardous area location (potentially explosive atmosphere), prevent sparks by proper tool selection and avoiding other types of impact energy.
- f. Proper care must be taken to avoid generation of static electricity on the non-conductive external surfaces of the equipment (e.g. rubbing of surfaces, etc.).
- g. Hytork XL actuators do not have an inherent ignition source due to electro-static discharge, but explosion hazard may be present due to the discharge of static electricity from other valve assembly components.
  - To avoid personal injury or property damage, make sure that the valve is grounded to the pipeline before placing the valve assembly into service.
  - Use and maintain alternate shaft-to-valve body bonding, such as a shaft-to-body bonding strap assembly.
- h. The paint protection must not exceed 200 µm if the actuator is used in a group IIC atmosphere. For group IIA or IIB atmospheres the paint protection must not exceed a thickness of 2 mm (0.08”).

#### ▲ WARNING - SURFACE TEMPERATURE

- The actuator’s surface temperature is dependent upon process operating conditions. Personal injury or property damage, caused by fire or explosion, can result if the actuator’s surface temperature exceeds the acceptable temperature for the hazardous area classification. To avoid an increase of instrumentation and/or accessory surface temperature due to process operating conditions, ensure adequate ventilation, shielding, or insulation of these actuator components installed in a potentially hazardous or explosive atmosphere.

### 2.3 Temperature range for (potential) explosive areas

Table 3.

Ambient range	Temperature		Valid for actuator model
	ATEX class	TX (ATEX surface temperature)	
-20..75°C	T6	T85°C (185°F)	Standard Temperature models
-20..80°C	T5	T90°C (194°F)	
-20..80°C	T1...T4	T90°C (194°F)	
-20..75°C	T6	T85°C (185°F)	High Temperature models
-20..90°C	T5	T100°C (212°F)	
-20..120°C	T1...T4	T130°C (266°F)	
-40..75°C	T6	T85°C (185°F)	Low Temperature models
-40..80°C	T5	T90°C (194°F)	
-40..80°C	T1...T4	T90°C (194°F)	
-20..250°C for 2 hours	T2	T260°C 500°F)	Tunnel application models

#### NOTE:

- a. The specified values are valid with the following conditions:
  - Maximum working frequency of the actuator is 1Hz at a maximum of 50 cycles per hour and at maximum load.

### 3 Operating Media, Pressures and Temperatures

#### 3.1 Operating media

- a. Use clean, dry or lubricated air or inert gas.
- b. Maximum pressure : 8 barg / 116PSI.

**NOTE:**

On applications where the spring stroke of single acting actuators is pneumatically operated, the maximum pressure is 6.5 bar / 95PSI.

- c. Dew point 10 K below operating temperature.
- d. For subzero applications take appropriate measures.

#### 3.2 Operating Temperature range

Using standard seals and greases the operating temperature range is -20°C to + 100°C (-4°F to +212°F) as is indicated on the product label. Other medias and temperatures may be used but consult your local Hytork supplier for confirmation as to suitability.

### 4 Actuator to Valve Installation

The Pinion drive, coupling device and Valve Stem should be centered and concentric to prevent any side loading to the Pinion Radial Bearing and Valve Stem Seat area. Ensure that the coupling shaft to be operated is a tight but free sliding fit into the female drive in the Actuator Pinion (19).

#### 4.1 Bi-directional Travel Stops

Hytork XL actuators have two travel stops (22, 23 and 24) for setting accurately the travel and the open and closed positions. XL2586 and XL4581 can be fitted with the optional Bottom Stop Block for setting the travel.

The actuator has a factory set stroke of 90°. The adjustable stroke range of the actuator is :

- at closed (0°) position : -3° to +7°
- at open (90°) position : -83° to +93°

**NOTE:**

If the actuator is assembled for reverse operation, instead of standard operation, Stop “1” will adjust the “open” position and stop “2” the “closed” position.

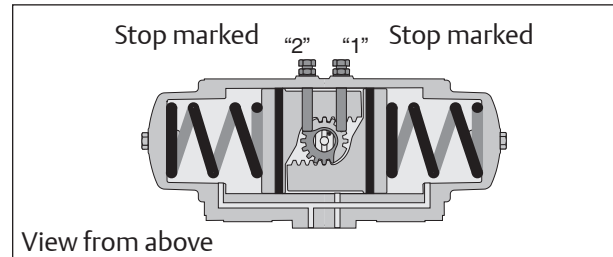

Fig. 1 Travel Stops

#### 4.2 Travel Stop Adjustments

1. Operate valve/actuator assembly to the open position.
2. Remove air supply.
3. Slacken locknut (24) on the “closed” stop (marked “2”).
4. Turn the “closed” stop clockwise to reduce or counter clockwise to increase the travel.
5. Tighten the lock nut.
6. Connect air and check that the position is correct. If not repeat from 2.
7. Operate valve/actuator assembly to the “closed” position.
8. Remove air supply.
9. Adjust “open” travel stop (marked “1”) as from step 3 to 6.

### 5 Piping Instructions

All Actuators can be either piped with solid or flexible tubing with the solenoid valve mounted remotely from the actuator or by mounting a NAMUR designed solenoid valve DIRECTLY onto the NAMUR mounting pad on the side of the actuator. (See Fig. 2)

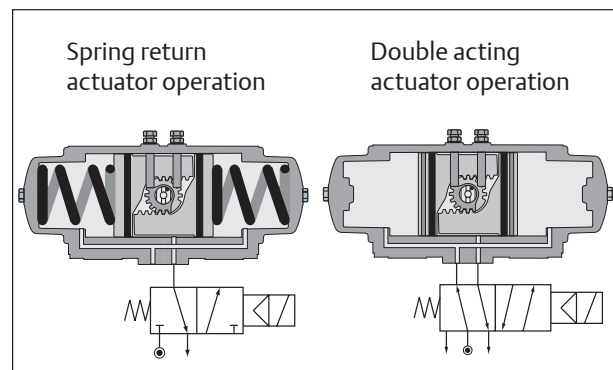

Fig. 2 Solenoid Operation

## 6 Solenoid Valves on Spring Return Actuators

It is recommended that on Spring Return Actuators, the Hytork "CATS" Solenoid Valves are used. These Valves are specially designed to prevent contamination of the internals of the Actuator by dirt from the atmosphere. This increases the working life of the Actuator which reduces down time and maintenance periods. (See Fig. 3)

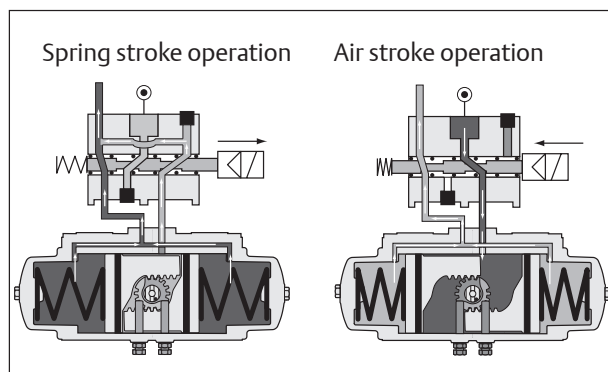

Fig. 3 Hytork "CATS" Solenoid Valve

## 7 Position Feedback

All position feedback or positioning accessories, that comply to the VDI/VDE 3845 (NAMUR) standard, can be mounted easily on top of Hytork XL actuators. To access the pinion top, remove the position indicator.

## 8 Spares Recommendations

When disassembling and carrying out maintenance work on the XL Actuator, a Hytork Spares Kit must be used to replace all 'O' Rings, DURASTRIP Bearings, Washers etc. This Kit is available from Emerson or its Stocking Distributors.

## 9 Disassembly Procedure

### 9.1 End cap and springs disassembly on Spring Return actuators

1. Release Locking Nuts (24) and remove both Travel Stops (22) and Thread Seals (23) or 'O'-rings (23a).
2. Remove the Indicator (7) from the top of the Pinion (19) For XL26 to XL221 use an Allen key size 4mm. For the larger sizes the Indicator can be pulled from the pinion top.
3. Remove both Sealing Bolts (28) and seals (29) from the End Caps (21).

4. Place both the Hytork Retractor Rods through the hole in the End Caps and screw the Rods into :
  - For XL 26 to XL 681 the Pistons (20)
  - For XL 1127 to XL4581 the Retractor plate (20a, see also Fig. 4) until travel is stopped (DO NOT OVERTIGHTEN) and take care the nut and washer being free of the End Cap face.
5. Turn back the Rod 1/2 turn.
6. Screw the adjusting nut and washer by hand clockwise down the Retractor Rod until they come up against the face of the End Cap.
7. Prevent the "hold-nuts" to rotate by one wrench. Use another wrench, to screw both adjusting nuts half turn at a time (see Fig. 4) clockwise down the Rods until the end cap loosens (Maximum; approximately two complete turns). This draws the:
  - For XL 26 to XL681 the Pistons (20)
  - For XL 1127 to XL4581 the Retractor plate (see also Fig. 4) to the end caps (21) and compresses the springs. This Spring-compression, releases the Spring force and unlocks the SAFEKEY for removal.
8. Rotate the Caps to ensure that the Springs are retracted; if the Cap will not turn easily, a gentle tapping with a plastic hammer against the endcap will loosen the end cap.
9. Unscrew the two slotted SAFEKEYS (13/14), and gently pull each SAFEKEY from the Body. If the SAFEKEY resists removal, gently tap the End Cap with a soft hammer to assist release.
10. When both SAFEKEYS have been removed, use a wrench to rotate the Pinion, driving the pistons (20) apart until they partially push the End Caps from the Body.
  - For XL 26 to XL681 the Pistons (20), springs and end cap will come out.
  - For XL 1127 to XL4581 the Retractor plate, springs and end cap will come out.

11. To keep the Spring Pack Assembly intact (see Fig. 4), leave the Retractor Rod in place. To disassemble the Spring Pack, unscrew the adjusting nut on the Retractor Rod relieving the Spring force, while preventing the rod from turning with a wrench on the hold nuts.

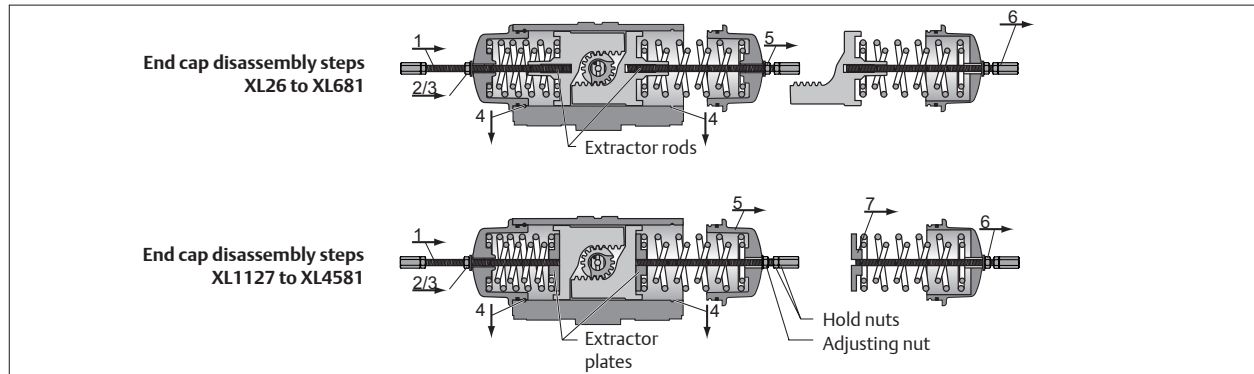

Fig. 4 End Cap Disassembly

## 9.2 Changing spring sets on XL26 to XL681

If only the springs set of the actuator has to be changed, perform steps 1 to 9. These steps can be performed at both end caps simultaneously or at one end cap only. After step 9 unscrew the adjusting nut on the Retractor Rod relieving the Spring force, while preventing the rod from turning with a wrench on the hold nuts.

## 9.3 End cap disassembly on Double Acting actuators

Remove the SAFEKEY as described previously. The Retractor Rod is not required for Double Acting Actuators. Remove the End Caps by pulling them free from the Body keeping them square to the end face of the Body.

## 9.4 Piston disassembly

Rotate the Pinion using a wrench to drive the Pistons apart and remove from the Body by pulling the Pistons.

## 9.5 Pinion disassembly

Remove the snap ring (Circlip) (6), Thrust Washer (25) and DURASTRIP Thrust Bearing (5) from the top of the Pinion and CAREFULLY push the Pinion from the Body through the bottom. Take care that the Pinion does not damage the pinion bores on removal. If necessary, remove any burrs, etc. from the top of the Pinion before removal. Carefully remove Pinion Top Bearing (9) from the Body.

## 9.6 Inspection

Clean and examine all parts for damage and wear. Emerson recommends 'O' Rings, DURASTRIP Bearings, SAFEKEYS, Washers, etc. are replaced using a Hytork XL Spares Kit.

## 10 Assembly Instructions

### NOTE:

Check the product coding on the actuator's product labels to define which type of grease to use.

For standard actuators  
(-20°C to +80°C / -4°F to +176°F):  
Castrol High Temperature Grease or  
Rocol Sapphire Premier grease (or equivalent)

For low temperature operation  
(-40°C to +80°C / -40°F to +176°F):  
Castrol Tribol GR TT 1 PD  
(previously known as Castrol OPTITEMP TT1)  
or LG2 grease (or equivalent).

For high temperature operation  
(-20°C to +120°C / -4°F to +250°F):  
Castrol High Temperature Grease or  
Rocol Sapphire Premier grease (or equivalent)

### 10.1 Pinion Assembly

1. Lightly grease all 'O' Rings, 'O' Ring grooves, bearing grooves and Pinion.
2. Assemble the Top Pinion Bearing (9) to the Pinion, ensuring that the recess openings are facing away from the gear form, then assemble items (8), (17) and (18).
3. Lightly grease the Pinion bores in the Body (11) and insert the Pinion being careful not to damage the 'O' Rings.
4. When the Pinion is in place, install the DURASTRIP Thrust Bearing (5), Thrust Washer (25) and the snap ring (Circlip) (6) into the narrow groove at the top of the Pinion (ensuring the snap ring fits properly into the groove).
5. Only open the snap ring (Circlip) enough to just clear the Pinion diameter as opening too far will damage the snap ring. If damage occurs replace with a new part.

### NOTE:

The snap ring (Circlip) has one side with bevelled edges which must go DOWN onto the Thrust Washer (25); the square edge side must face UPWARDS.

### 10.2 Alignment of pinion for correct piston assembly

Standard rotation is clockwise with the Pistons moving towards each other (When viewed from above the slot at the top of the Pinion, see Fig. 5).

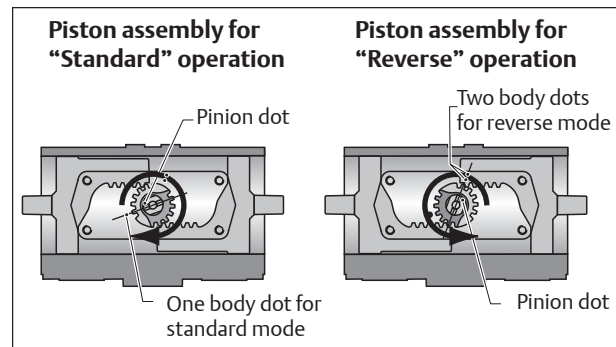

Fig. 5 Pinion Alignment

## 10.3 Piston Assembly

### 10.3.1 Clockwise rotation

(Pistons moving inwards, Fig. 5).

6. Align the Pinion by lining up the center of the NAMUR slot in the top of the Pinion with the single dot on the Body. The top of the Pinion is marked with a single identification dot to indicate the correct orientation of the stop faces.
7. Lightly grease all Piston grooves, gear form and Piston 'O' Rings (4) and fit the 'O' Ring (4) and Wear Ring (3) to the Piston.
8. Fit the Bearing Block (10) to the back of the Piston.
9. Grease the Actuator body bore.
10. Insert the Pistons into the bore, ensuring the piston racks line up with the pinion gear. (The part number in the front face of the Piston must be lined up parallel to the Pinion).
11. Push both Pistons together until they are both in contact with the Pinion, so that when the Pinion is rotated clockwise the Pistons are drawn together. When the Pistons are together and the racks are correctly engaged with the Pinion, the top Pinion drive flats should be at right angles to the axis of the Body.

### 10.3.2 Counter-Clockwise rotation

(Pistons moving inwards, Fig. 6).

12. Align the NAMUR slot in the top of the Pinion with the two dots on the Body and assemble the pistons so that the Pinion rotates anti-clockwise as the Pistons are drawn together.

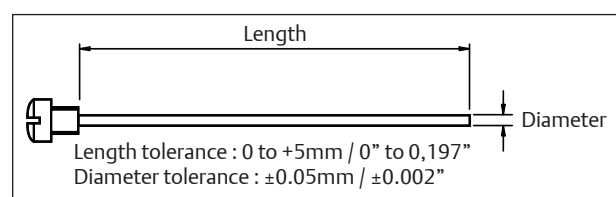

Fig. 6 SAFEKEY Dimensions



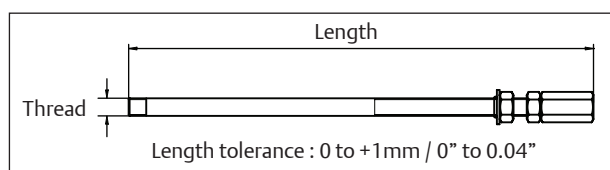

Fig. 7 Retractor Rod Dimensions

Table 4. SAFEKEY Dimensions

Model	(in mm)		(in inches)	
	Length	Diam.	Length	Diam.
XL26	157	3.175	6.18	0.125
XL71	217	3.175	8.54	0.125
XL131	267	3.175	10.51	0.125
XL186	282	3.175	11.1	0.125
XL221	317	3.175	12.48	0.125
XL281	367	3.175	14.45	0.125
XL426	377	3.175	14.84	0.125
XL681	437	3.175	17.2	0.125
XL1127	517	3.175	20.35	0.125
XL1372	572	3.175	22.52	0.125
XL2856	707	3.175	27.83	0.125
XL4581	937	4.978	36.89	0.196

Model	Thread	Length	
		mm.	inch.
XL26	1/4-20 UNC	215	8.46
XL71	1/4-20 UNC	215	8.46
XL131	1/4-20 UNC	215	8.46
XL186	1/4-20 UNC	215	8.46
XL221	5/16-18UNC	225	8.86
XL281	M10	210	8.27
XL426	M8	278	10.94
XL681	M12	363	14.29
XL1127	M12	416	16.38
XL1372	M12	416	16.38
XL2856	M20	500	19.69
XL4581	M20	600	23.62

## 10.4 Travel stop assembly

(See Fig. 1)

- With the Pistons together, screw in the CLOSING (cast identity number 2) Travel Stop (22), complete with Locking Nut (24) and Thread Seal (23), until it comes into contact with the Pinion stop face.
- Rotate the Pinion through 90° only, driving the Pistons apart and screw in the OPENING (cast identity number 1) Travel Stop (22), complete with Locking Nut and Thread Seal, until it comes into contact with the pinion stop face.  
For individual position requirements see chapter 4.

## 10.5 End cap assembly on double acting actuators

- Install the SAFEKEY 'O' Ring seals (12) to the SAFEKEY heads (13).
- Lightly grease the End Cap 'O' rings (2), the End Cap grooves and the ends of the Body bore.
- Taking one of the End Caps install its 'O' Ring and insert it into the Body.
- Holding the SAFEKEY close to the entry hole (cast identity letter C or D) to prevent kinking, insert the SAFEKEY into the hole and gently push into place.
- With the SAFEKEY Head in contact with the Body, tighten with a screw driver to gently compress the 'O' Ring and create a pressure seal.
- Repeat the operation for the other End Cap. With the Pistons together, mount the Position Indicator (7) to the top of the Pinion.

## 10.6 Spring Return Actuators

### 10.6.1 Spring set adjustments

The actual selection of the correct spring set can be done by either referring to the torque charts given in the literature on Spring Return Actuators or by consulting your local Hytork representative. After selecting the appropriate spring set arrange the springs as indicated below.

Table 5. Spring Rating Chart

Spring set	Side of actuator	Outer	Inner
S40	Left	S20	
	Right	S20	
S50	Left	S30	
	Right	S20	
S60	Left	S30	
	Right	S30	
S70	Left	S20	S20
	Right	S30	
S80	Left	S20	S20
	Right	S20	S20
S90	Left	S30	S20
	Right	S20	S20
S1C	Left	S30	S20
	Right	S30	S20

Spring Colour Coding

S20 Inner	=	Green
S20 Outer	=	Pink
S30 Outer	=	Brown

### 10.6.2 Installing the Springs

1. **For XL 1127 to XL4581** place the Retractor plate on top of the piston.
2. Insert the Springs (26/27) into the face of the Piston and then the End Cap onto the Springs.
3. Pass the correct Hytork Retractor Rod through the End Cap (Fig.6) and screw it into
  - **For XL 26 to XL681** the Pistons (20)
  - **For XL 1127 to XL4581** the Retractor plate.
4. Line up the End Cap so that the safety symbol is correctly positioned for easy reading.
5. Prevent the “hold-nuts “ to rotate by one wrench. Use another wrench, to screw the adjusting nut on the Hytork Retractor Rod in until the End Cap is completely engaged in the Body.
6. It will be necessary to push the End Cap into the Body to overcome the ‘O’ Ring compression.
7. When the End Caps are in place and the SAFEKEYS fitted correctly, remove the Hytork Retractor Rods and replace the Sealing Bolts (28) and seals (29).

## 11 Testing the Hytork Actuator

Using compressed air at 80-100 psi (5.5 - 7 bar) check the seal areas with soapy water, ensuring there are no leaks and that the Pinion rotates smoothly over its full travel.

### 11.1 Testing and Cycling of Infrequently Used or Stored Actuators

Actuators not in current use (i.e. Actuators in storage or stock and/or not operated for at least a 3 month period), should be cycled a minimum of ten times and tested against the possible ‘pre-set’ of the seals. This is a safety precaution recommended by the Seal manufacturers.

## 12 Retractor Rods

### 12.1 Spring Removal System Board

Hytork’s “SPRING REMOVAL SYSTEM BOARD” contains a full set of Retractor Rods so that any size of Actuator can be disassembled on site. Standard spare parts kits for XL26 to 221 contain the required Retractor Rods. For XL281 to XL4581 separate Retractor Rod kits are available. These Rods are not included in the spare parts kits but are separately available. Ask your local Hytork representative or Stocking Distributor of Hytork Products for details.

### ▲ WARNING - USE APPROVED TOOLS

- The Hytork Retractor Rod tools are specially designed for the safe removal of the Spring Return End Cap modules. Only Hytork manufactured or approved rods are to be used for Spring End Cap removal.
- As with any threaded tool that is used frequently, Retractor Rods should be checked to ensure that the threads are not worn or damaged in any way and greased regularly. Any damaged or worn Rods must not be used and must be destroyed.
- Retractor Rods must be made to the design specification for safety reasons. Emerson can not take any responsibility for any other design.

## 13 Service

It is the policy of Emerson to give the best possible service to our customers. We are happy to assist you in any way we can and if you have any questions about Hytork Actuators or other Hytork Products please do not hesitate to contact any Actuation Technologies Center of Emerson or your local Hytork Stocking Distributor.

## 14 Grease Specification

Check the product coding on the actuator’s product labels to define which type of grease to use.

- \* For standard actuators (-20°C to +80°C / -4°F to +176°F):
  - Castrol High Temperature Grease or Rocol Sapphire Premier grease (or equivalent)
- \* For low temperature operation (-40°C to +80°C / -40°F to +176°F):
  - Castrol Tribol GR TT 1 PD (previously known as Castrol OPTITEMP TT1) or LG2 grease (or equivalent).
- \* For high temperature operation (-20°C to +120°C / -4°F to +250°F):
  - Castrol High Temperature Grease or Rocol Sapphire Premier grease (or equivalent)

## 15 Parts and Materials

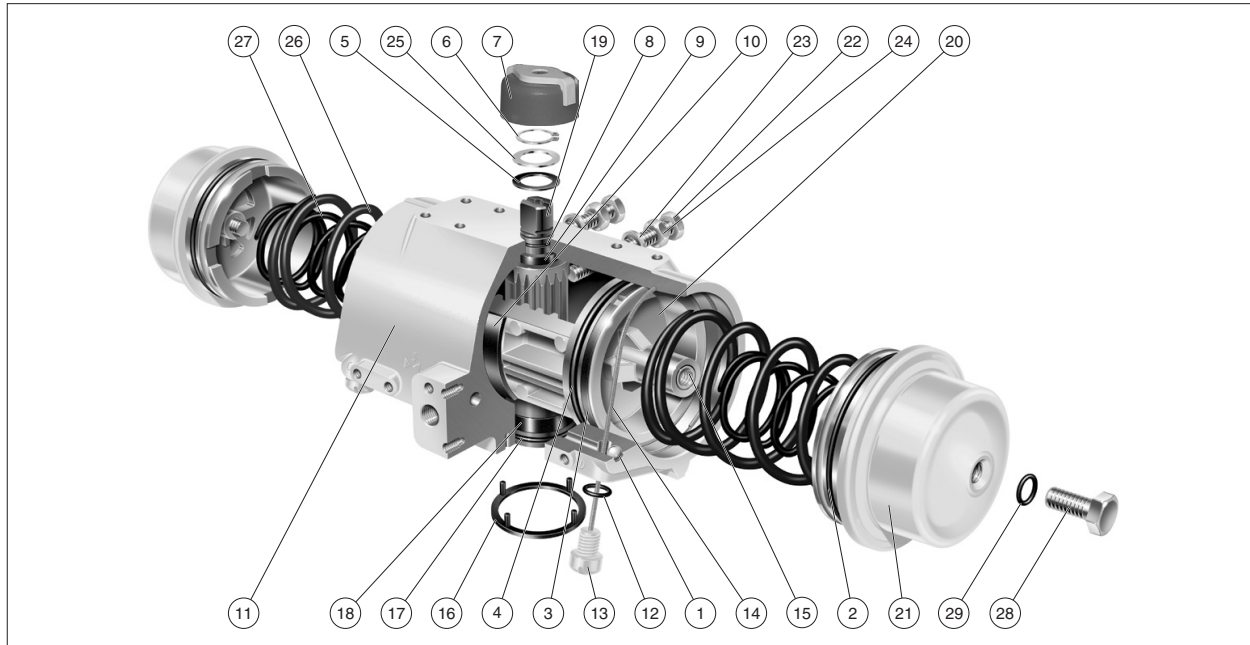

Fig. 8 Hytork XL Actuator Parts

Table 6. Parts and Materials

Pos.	Description	Material	Qty	Note:
1	Ball Bearing	Chromium steel	2	-
2	'O' Ring (End Cap)	Nitrile	2	-
3	Wear Ring (Piston)	Acetal M90	2	-
4	'O' Ring (Piston)	Nitrile	2	-
5	Thrust Bearing (Circlip)	Acetal M90	1	-
6	Circlip	Springsteel	1	-
7	Indicator	Nylon	1	-
7a	Indicator screw	Stainless steel	1	3
8	'O' Ring (Pinion top)	Nitrile	1	-
9	Bearing (Pinion top)	Acetal M90	1	-
10	Bearing block (Piston)	Acetal M90	2	-
11	Body	Aluminum alloy	1	-
12	'O' Ring (SAFEKEY)	Nitrile	2	-
13	SAFEKEY Head	Grivory	2	-
14	SAFEKEY Wire	Stainless steel	2	-
15	Thread Insert	Steel	2	-
16	Location Ring	Acetal	1	-
17	'O' Ring (Pinion bottom)	Nitrile	1	-
18	Bearing (Pinion bottom)	Acetal M90	1	-
19	Pinion	Steel	1	-
20	Piston	Aluminum alloy	2	-
20a	Retractor plate	Aluminum alloy	2	1
21	End Cap (DA & SR)	Aluminum alloy	2	2
21a	End Cap DA	Aluminum alloy	2	1
22	Travel Stop	Stainless steel	2	5
23	Thread Seal	Steel/Rubber	2	3/6
23a	'O' Ring (Travel Stop)	Nitrile	2	4
23b	Washer (Travel Stop)	Stainless steel	2	4
24	Locking Nut	Stainless steel	2	5
25	Thrust Washer (Circlip)	Stainless steel	1	-
26	Spring Outer	Spring steel	2	-
27	Spring Inner	Spring steel	2	-
28	Sealing Bolt (End Cap)	Steel	2	-
29	'O' Ring (Sealing Bolt)	Nitrile	2	-

**Notes:**

1	on XL 1127 to 4851	4	on XL 281 to XL 1372
2	on XL 26 to XL 681	5	on XL 26 to XL 1372
3	on XL 26 to XL 221	6	on XL 26/71 equipped with extra nylon washer

**World Area Configuration Centers (WACC) offer sales support, service, inventory and commissioning to our global customers. Choose the WACC or sales office nearest you:**

***NORTH & SOUTH AMERICA***

19200 Northwest Freeway  
Houston TX 77065  
USA  
T +1 281 477 4100  
F +1 281 477 2809

Av. Hollingsworth  
325 Iporanga Sorocaba  
SP 18087-105  
Brazil  
T +55 15 3238 3788  
F +55 15 3228 3300

***ASIA PACIFIC***

No. 9 Gul Road  
#01-02 Singapore 629361  
T +65 6777 8211  
F +65 6268 0028

No. 1 Lai Yuan Road  
Wuqing Development Area  
Tianjin 301700  
P. R. China  
T +86 22 8212 3300  
F +86 22 8212 3308

***MIDDLE EAST & AFRICA***

P. O. Box 17033  
Dubai  
United Arab Emirates  
T +971 4 811 8100  
F +971 4 886 5465

P. O. Box 10305  
Jubail 31961  
Saudi Arabia  
T +966 3 340 8650  
F +966 3 340 8790

24 Angus Crescent  
Longmeadow Business Estate East  
P.O. Box 6908 Greenstone  
1616 Modderfontein Extension 5  
South Africa  
T +27 11 451 3700  
F +27 11 451 3800

***EUROPE***

Berenyi u. 72- 100  
Videoton Industry Park  
Building #230  
Székesfehérvár 8000  
Hungary  
T +36 22 53 09 50  
F +36 22 54 37 00

For complete list of sales and manufacturing sites, please visit [www.emerson.com/actuationtechnologieslocations](http://www.emerson.com/actuationtechnologieslocations) or contact us at [info.actuationtechnologies@emerson.com](mailto:info.actuationtechnologies@emerson.com)

[www.emerson.com/hytork](http://www.emerson.com/hytork)

©2018 Emerson. All rights reserved.

The Emerson logo is a trademark and service mark of Emerson Electric Co. Hytork™ is a mark of one of the Emerson family of companies. All other marks are property of their respective owners.

The contents of this publication are presented for information purposes only, and while every effort has been made to ensure their accuracy, they are not to be construed as warranties or guarantees, express or implied, regarding the products or services described herein or their use or applicability. All sales are governed by our terms and conditions, which are available on request. We reserve the right to modify or improve the designs or specifications of our products at any time without notice.

**HYTORK™**

  
**EMERSON™**